

# IMPROVING CROSS REGULATION OF MULTIPLE OUTPUT FLYBACK CONVERTERS

JOE MARRERO

Principal Engineer Power Management Applications

National Semiconductor 2900 Semiconductor Drive, Santa Clara,  
CA 95052-8090 ( 408 ) 721-3183

## Abstract

Cross regulation has been a serious limitation in using Flyback converters with multiple outputs. This paper shows a simple technique which minimizes the problem by adding small external inductors. These inductors are used to control the rate at which the secondary current will change when the switch turns off. By controlling the rate of change, both line and load cross regulation will improve considerable.

## Introduction

Theoretically cross-regulation in a flyback converter should be better than that of a forward converter, since an additional magnetic (inductor) is needed for the forward converter. In practice this is not the case. Due to the storing of energy during the on time,  $T_{on}$ , the input current will reach some maximum peak,  $I_p$ , at the end of  $T_{on}$ . This current will be transferred to the secondary when the power switch is turned “off”. The important point in understanding the cross-regulation is how this transferred current is shared between the secondaries. It will be shown that initially the majority of the current will be transferred to the output which has the smallest leakage inductance. If this output is not used by the feedback to control the PWM then peak detection will occur. If this output is used as the feedback then the duty cycle will be reduced, which in turn will reduce the other outputs.

Another important feature involving cross-regulation is selecting the number of turns for the non-feedback outputs. Typically, to keep the outputs within a certain tolerance it is necessary to add or delete a turn and /or adjust the feedback output. This will increase the select and test time it will take to bring in all to outputs within their specified tolerance. In many cases the cross-regulation problem leads to the use of additional linear and /or switching regulators for several outputs that are out of tolerance.

## Cross-regulation for a dual output

In order to see how the transferred current is initially distributed, when the switch is

turned off, we will reflect the second output,  $V_{o2}$ , to the output which is being feedback,  $V_{o1}$ , as shown in Figures 1 and 2.

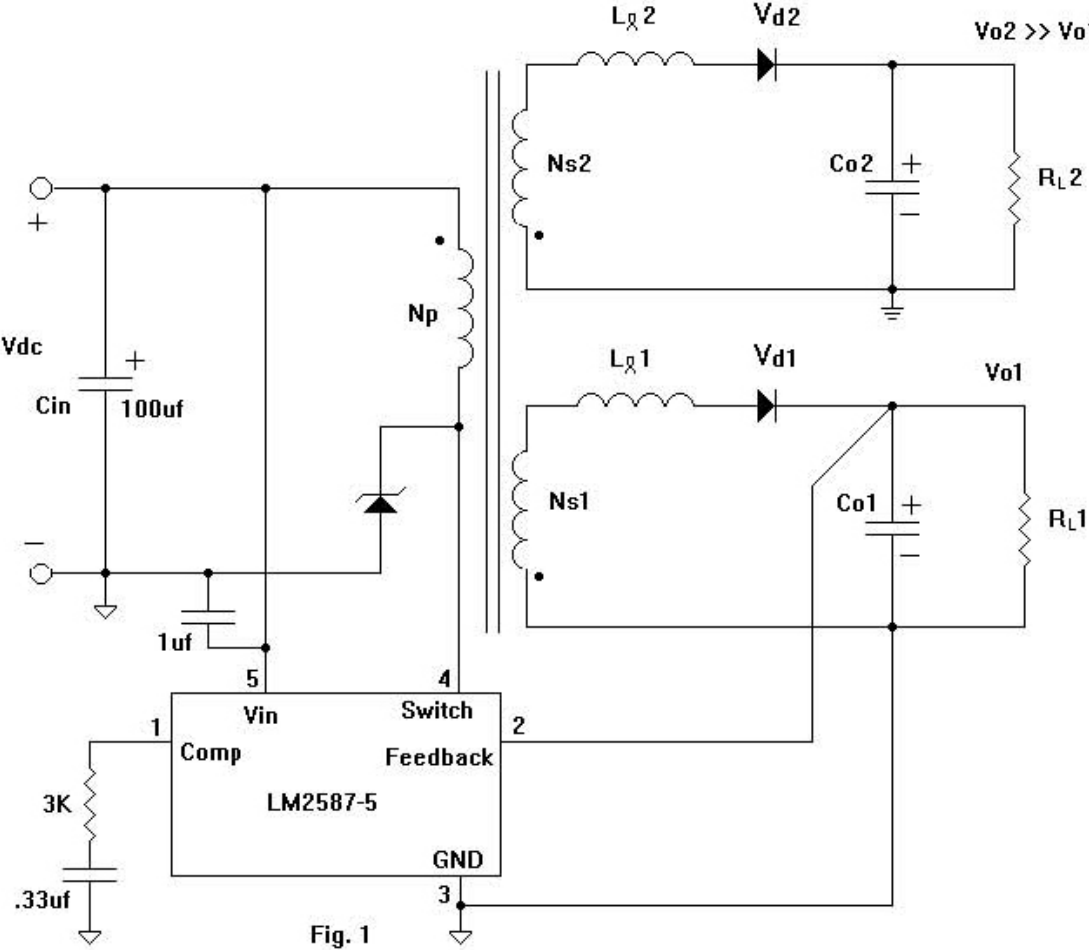

Fig. 1

Assuming that  $L_{\ell 2} = 2L_{\ell 1}$

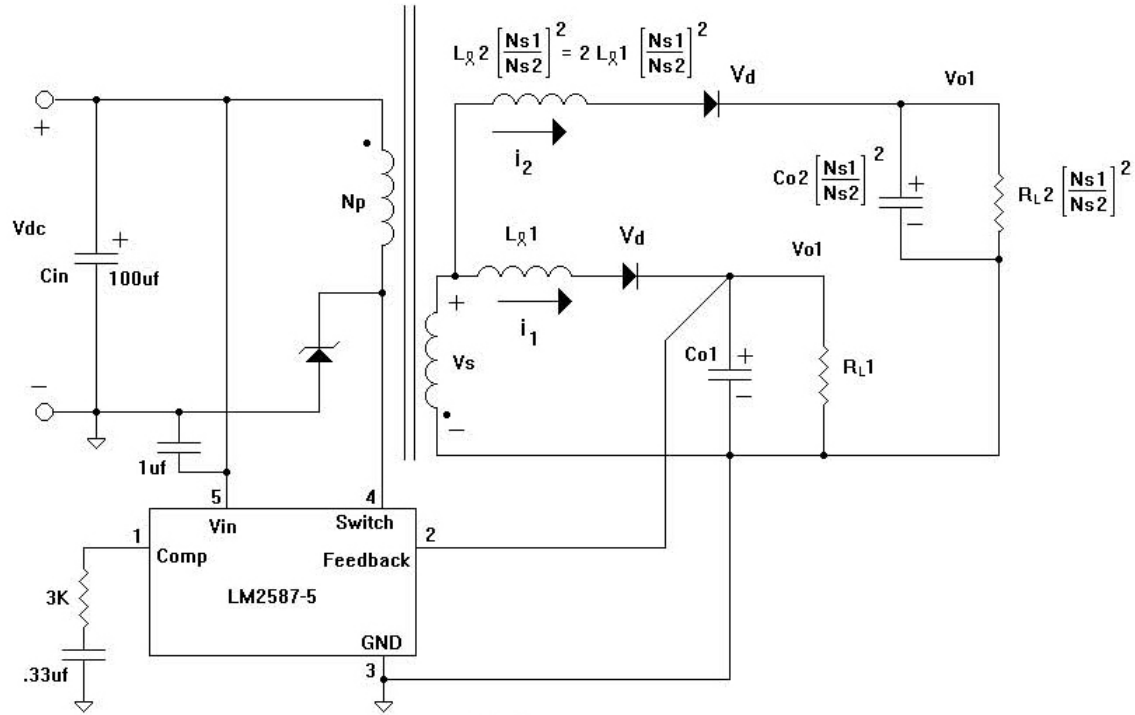

Fig. 2

We notice that if  $V_{d1}=V_{d2}=V_d$  then the voltage across  $L_{r1}$  and  $L_{r2}$  will be the same. Call the voltage across the leakage inductors  $V_o=V_s-(V_{o1}+V_d)$ . Then as soon as the switch turns off, the transferred current will be distributed in accordance with Faraday's Law.

$$L_{r2} \left[ \frac{N_{S1}}{N_{S2}} \right]^2 \frac{di_2}{dt} = v_o$$

$$i_2 = \int di_2 = \int_0^t \frac{V_o}{2 L_{r1} \left[ \frac{N_{S1}}{N_{S2}} \right]^2} dt = \frac{V_o}{2 L_{r1} \left[ \frac{N_{S1}}{N_{S2}} \right]^2} t$$

The above equations are not exact since  $V_o$  is a function of time,  $t$ , and we treated  $V_o$  as a constant, however for understanding how the leakage effects the cross-regulation it is effective.

Similarly we calculate the current,

$$i_1 = \frac{V_o}{L_{r1}} t$$

$$\text{Let } m = \frac{V_o}{L_{r1}} \quad \text{Then } i_1 = m t$$

comparing the two currents we have;

$$i_1 = \frac{V_o}{L_{\alpha 1}} t = m t$$

$$i_2 = \frac{V_o}{2 L_{\alpha 1} \left[ \frac{N_{S1}}{N_{S2}} \right]^2} t = \frac{m}{2 \left[ \frac{N_{S1}}{N_{S2}} \right]^2} t$$

since  $V_{o2} \gg V_{o1}$ , as an example lets say  $V_{o2} = 50 \text{ V}$   
and  $V_{o1} = 5 \text{ V}$  then  $N_{S2} = 10 N_{S1}$

$$\text{Hence } \left[ \frac{N_{S1}}{N_{S2}} \right]^2 = \left[ \frac{1}{10} \right]^2 = \frac{1}{100}$$

$$\text{and } i_1 = m t$$

$$i_2 = \frac{m}{2 \left[ \frac{N_{S1}}{N_{S2}} \right]^2} t = \frac{m}{2 \frac{1}{100}} t = 50 m t = 50 i_1$$

Hence the initial current flowing in  $V_{o2}$  output is 50 times greater than the current in  $V_{o1}$  output. This will lead to output  $V_{o2}$  peaking well beyond 50 V.

Lets us observe a graph to see what happens to the current in both outputs;

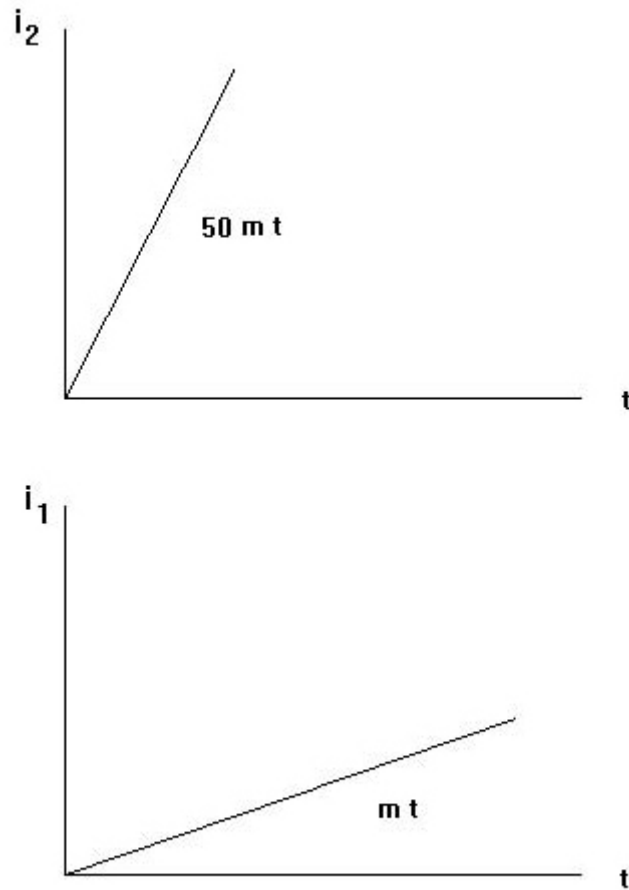

**Fig. 3**

When the current,  $i_1$ , finally equals the output current,  $I_o$ , and the charging current,  $I_c$ , ( $I_c$  is the current needed to charge the output capacitor  $C_{o1}$ ) a feedback signal is sent to terminate the duty cycle, but by this time the output  $V_{o2}$  has overshoot by a significant amount.

**Solution to cross-regulation problem**

If we add external inductors, as shown in Figure 4, such that the rate of change in both windings is the same, then there would be no ( or very little ) peaking.

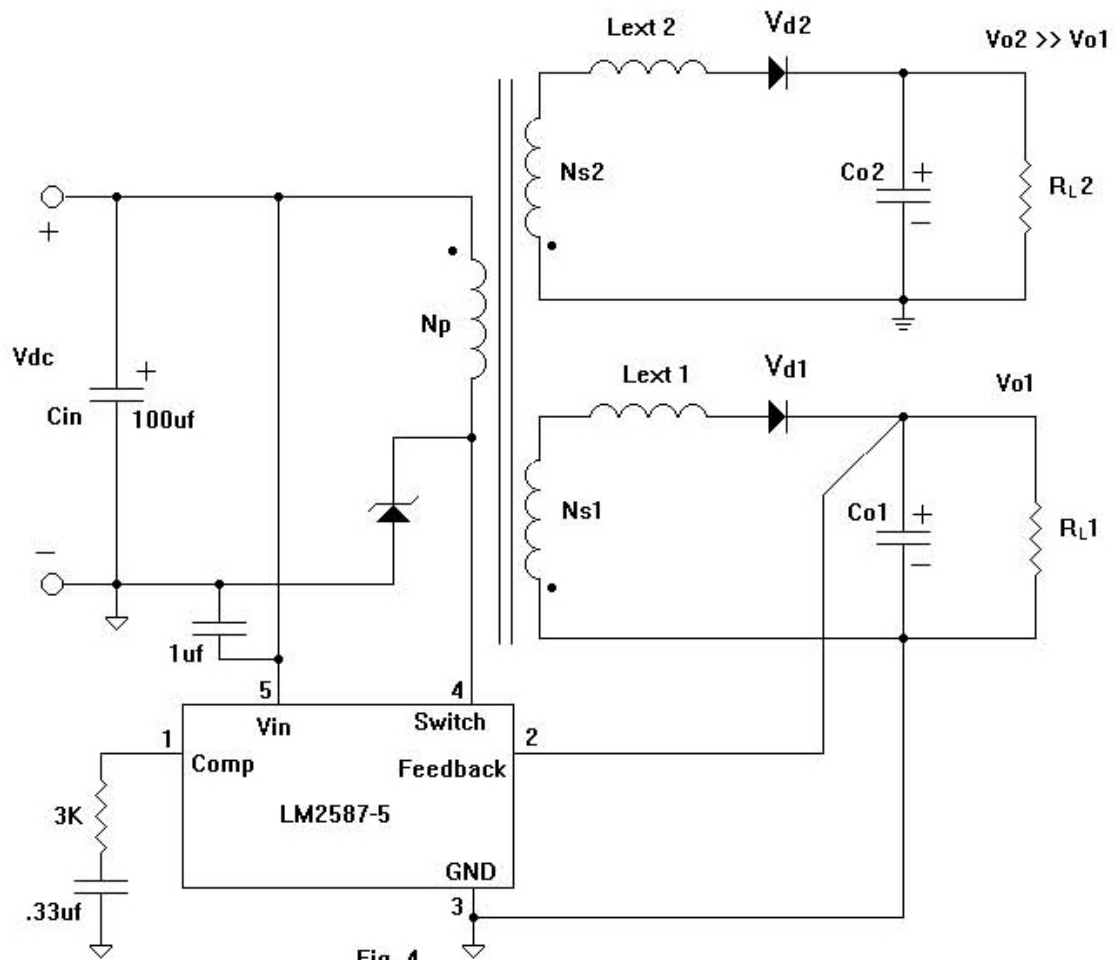

Fig. 4

Note:  $L_{ext2} \gg \text{Leakage2}$  and  $L_{ext1} \gg \text{Leakage1}$

To minimize cost,  $L_{ext1}$  is a one turn MPP or powdered iron core and  $L_{ext2}$  is a similar core with the following value;

$$L_{ext2} = \left[ \frac{N_{S1}}{N_{S2}} \right]^2 L_{ext1}$$

Now reflecting the output  $V_{o2}$  to  $V_{o1}$  as in Figure 5;

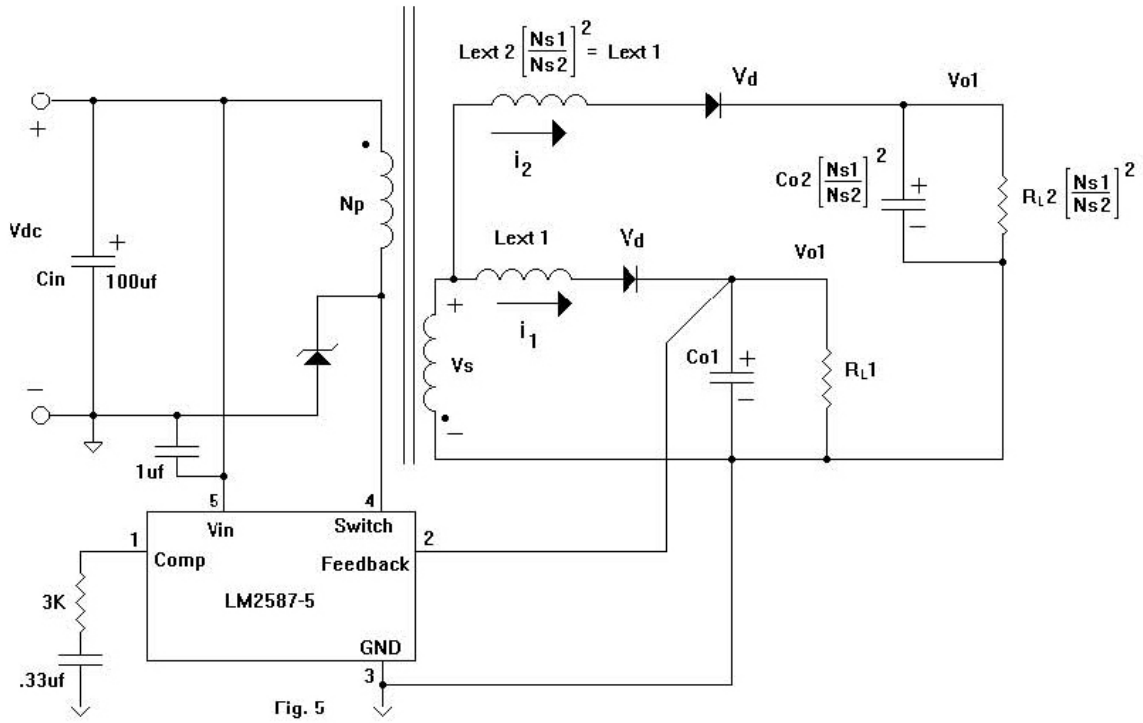

Fig. 5

In accordance to Faradays Law we have the same rate of change of current in both outputs.

$$i_1 = i_2 = \frac{V_o}{L_{ext 1}} t$$

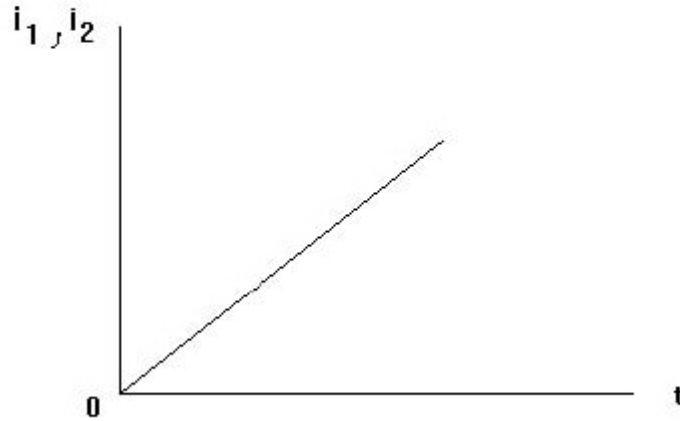
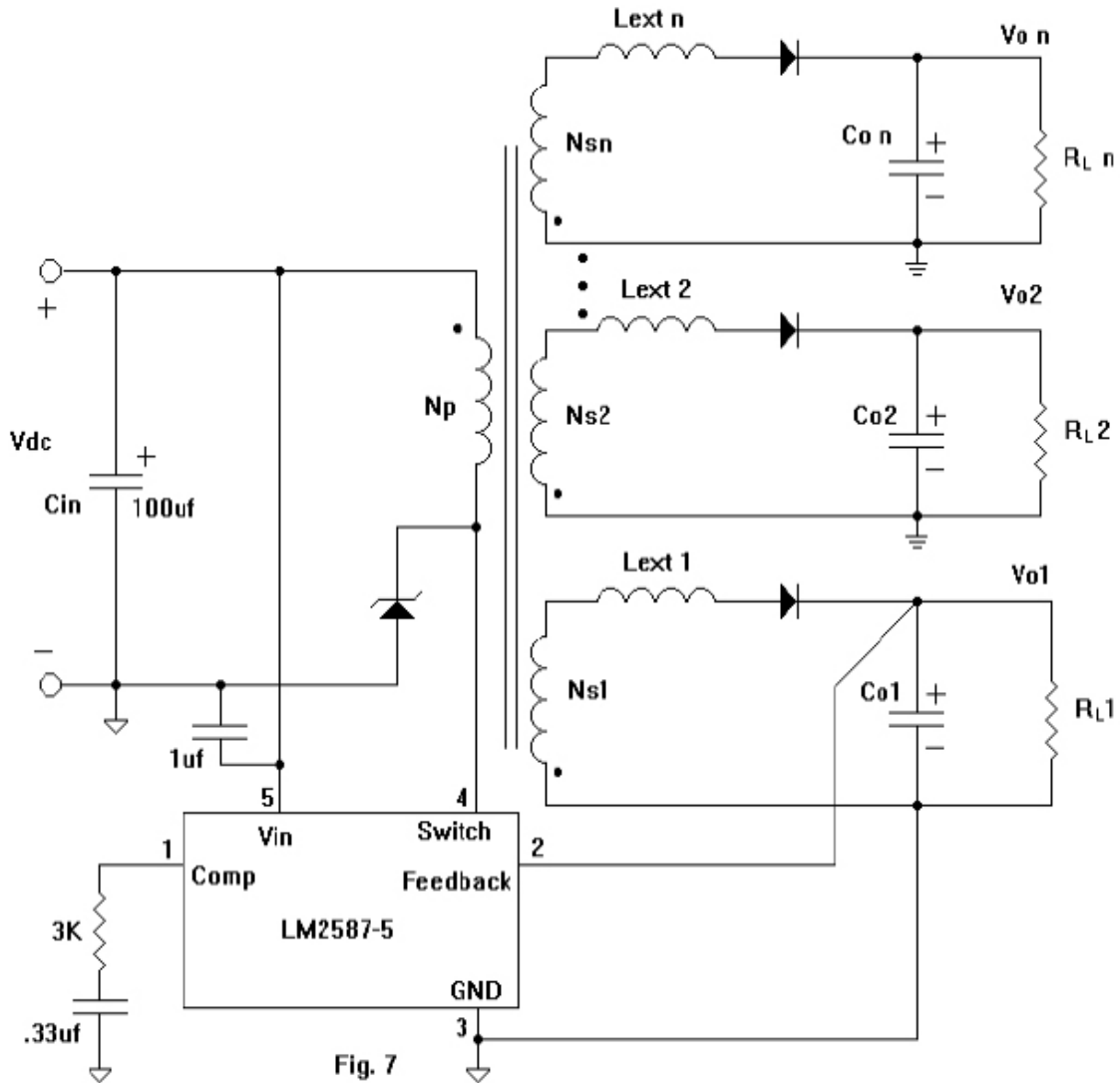

Fig. 6

Since we have the same rate of change, peak detecting will be reduced significantly. This will improve the cross-regulation problem.

## Multiple outputs

A similar situation and solution exists for multiple outputs as shown in Figure 7.



Reflecting all outputs to the feedback winding,  $V_{o1}$ , and selecting the external inductor follows;

$$L_{ext1} = \left[ \frac{N_{S1}}{N_{S2}} \right]^2 L_{ext2} = \left[ \frac{N_{S1}}{N_{S3}} \right]^2 L_{ext3} = \dots = \left[ \frac{N_{S1}}{N_{Sn}} \right]^2 L_{extn}$$

This will assure that the rate of change of current in all the outputs will be the same. This will improve the cross-regulation in all outputs by minimizing peak overshooting or undershooting any output.

This technique also minimizes selecting the “right” feedback voltage,  $V_{o1}$ , such that all outputs are within tolerance.

Ref:

- [1] J.Marrero, “Utilizing ripple steering in Forward and Flyback converters”, HFPC 1995, pp. 158-172.
- [2] J.Marrero, Courses on Intermediate and Advance switching power supply design.
- [3] J.Marrero and C. Peng , “Ripple current reduction circuit”,U.S. patent #5038263.
- [4] National Semiconductor Power IC’s databook 1995 edition, pages 3-116 to 3-139 ( LM2587 datasheet )