

DS91M047

125 MHz Quad M-LVDS Driver

Evaluation Kit

USER MANUAL

Part Number: DS91M047EVK NOPB

For the latest documents concerning these products and evaluation kit, visit lvds.national.com. Schematics and gerber files are also available at lvds.national.com

Overview

The purpose of this document is to familiarize you with the DS91M047 evaluation board, suggest the test setup procedures and instrumentation, and to guide you through some typical measurements that will demonstrate the performance of the device. The board enables the user to examine performance and all functions of the DS91M047 as a standalone device.

The DS91M047 is a high-speed quad M-LVDS differential line driver designed for multipoint applications with multiple drivers or receivers. The device conforms to TIA/EIA-899 standard. It utilizes M-LVDS technology for low power, high-speed and superior noise immunity.

Description

Figure 1 below represents the top layer drawing of the board with the silkscreen annotations. It is a 2.5 x 3 inch 4 layer printed circuit board (PCB) that features a single DS91M047 (U1) device.

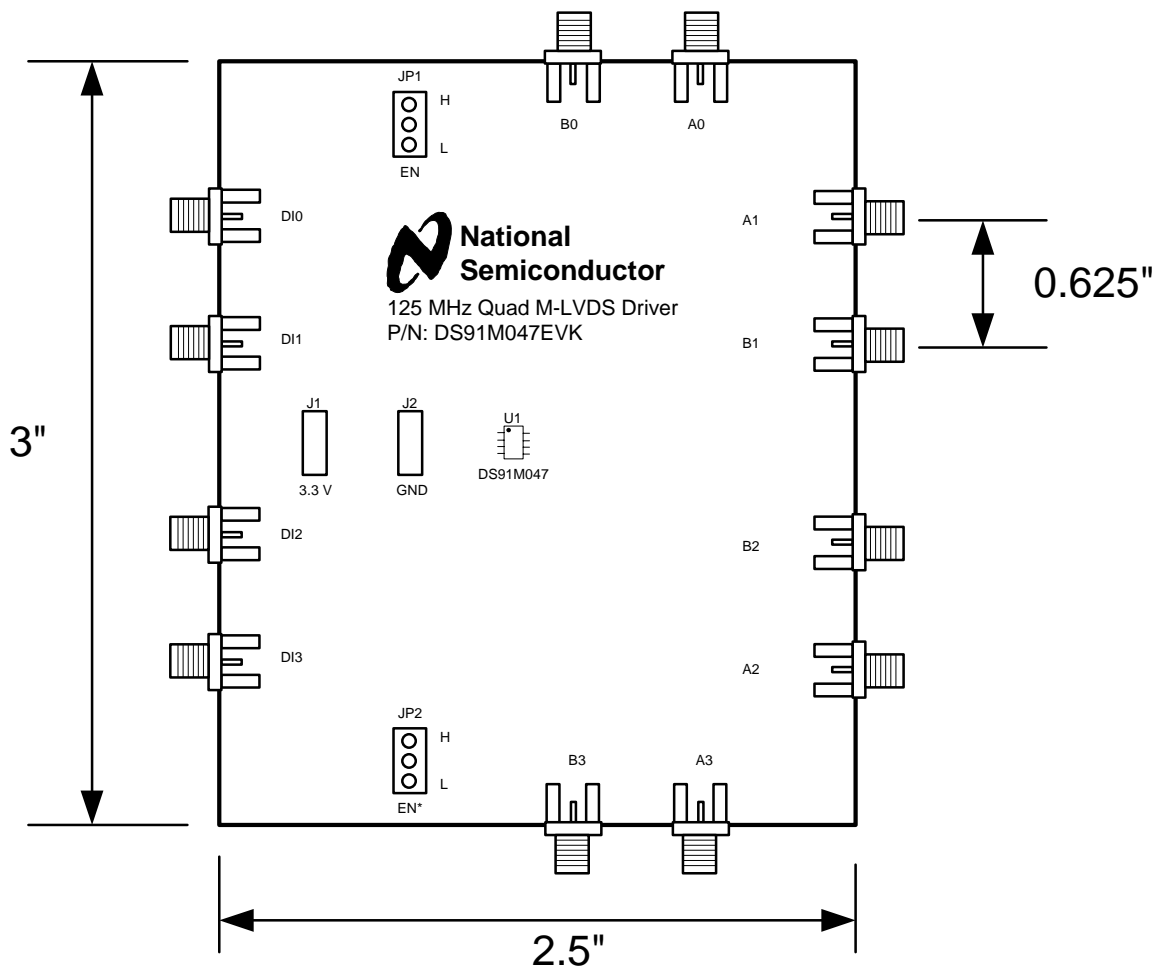

Figure 1 - DS91M047EVK Top View Drawing

DS91M047 Evaluation in a Point-to-Point Link

The following is a recommended procedure for using and evaluating the DS91M047EVK. Figure 2 depicts a typical setup and instrumentation used.

1. Select a single DS91M047 evaluation board.
2. Apply the power to the board (3.3 V typical) between J1 and J2 power tabs, observe the value of I_{CC} , and compare it with the expected value (refer to the datasheet) to ensure that the devices are functional.
3. Enable U1 driver outputs. This is accomplished by setting the EN pin to VDD (JP1) or EN* pin to GND (JP2).
4. Connect a signal source to one of the driver inputs (DI0-3).
5. Connect one of the U1 outputs (A0-3/B0-3) to an oscilloscope and observe the waveforms.

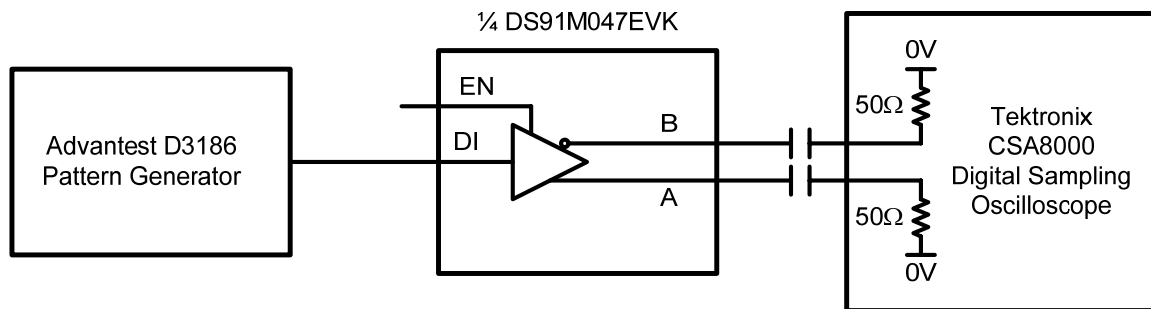

Figure 2 – DS91M047 Test Setup

Figure 3 shows an eye diagram acquired at the output of the DS91M047 driver loaded with a 100-ohm resistor. The generator connected to the driver input simulated a 100 Mbps PRBS-7 NRZ.

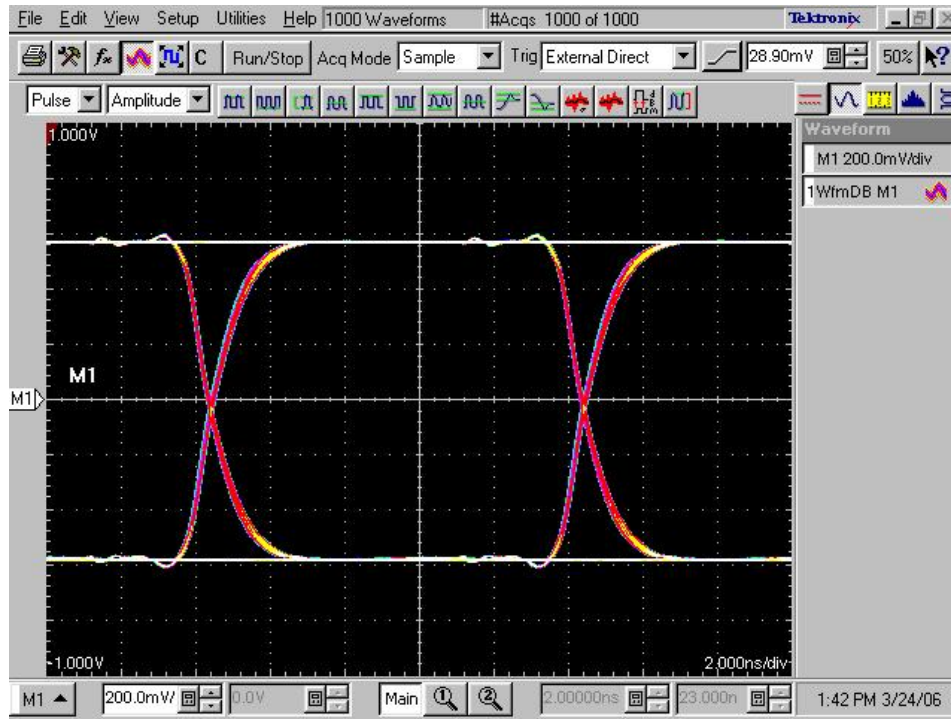

Figure 3 – DS91M047 Output

ENERCON - BILL OF MATERIALS

TITLE:

**NATIONAL SEMICONDUCTOR
PCBA, DS91M047EVK, ROHS
DS91M047**PL Number: Z3250-01
Rev: 1
Rev By: BJ

Rev Date: 04/30/08

PL Status: Released

Main Product:
PCBA, DS91M047EVK, ROHS

Responsible Eng/Mgr:

Creator:
Arlene FoxCreation Date:
03/13/08

Item	Part Type	Part Number/Value	Mfg	NoSub	Description	Qty	SMT	Ref Des	Notes	Rev
1	PCB	P-06540R0	ENERCON			1				0
2										
3	SUBASY	Z3211-04	ENERCON		LABEL, MADE IN U.S.A.	1			Apply to bottom of PCBA	1
4										
5	IC	DS91M047TMA	NAT		125MHz Line Driver, SOIC16, Pb-Free	1	X	U1		0
6										
7	CAP	06035C103KAT	AVX		.01µF, 50V, ±10%, 0603, Ceramic, X7R, Pb-Free	2	X	C3,6		0
8	CAP	0603YC104KAT	AVX		.1µF, 16V, ±10%, 0603, Ceramic, X7R, Pb-Free	2	X	C2,4		0
9	CAP	TAJA106K016	AVX		10µF, 16V, ±10%, A-Case, Tantalum, Pb-Free	1	X	C1		0
10										
11	CONN	1287	KEYSTONE		Faston, Male, .250", Pb-Free	2		J1,2		0
12	CONN	142-0701-851	EMERSON		SMA, Jack Receptacle, 50 OHM, Pb-Free	12		SMA1-12		0
13	CONN	15-29-1024	MOLEX		Jumper Shunt, 2p, Gold, Pb-Free	2			Use on JP1,2 Pins 2&3	0
14	CONN	TSW-103-07-G-S	SAMTEC		Header, 3p, Male, .100"sp, Gold, Pb-Free	2		JP1,2		0
15										
16	STENCL	T-06543R0	ENERCON		STENCIL FABRICATION, TOP, DS91M047EVK/DS91M124E...	1				0
17										
18	REF	C-06541R0	ENERCON		FAB DWG, DS91M047EVK/DS91M124EVK/DS91M125EVK					0
19	REF	C-06542R0	ENERCON		PALLET DWG, DS91M047EVK/DS91M124EVK/DS91M125EVK					0
20	REF	S-06539R0	ENERCON		SCHEMATIC, DS91M047EVK/DS91M124EVK/DS91M125EVK					0
21										

ENERCON - BILL OF MATERIALS	TITLE: NATIONAL SEMICONDUCTOR PCBA, DS91M047EVK, ROHS DS91M047	PL Number: Z3250-01	Rev: 1	Rev By: BJ	Rev Date: 04/30/08	PL Status: Released
		Responsible Eng/Mgr:		Creator: Arlene Fox	Creation Date: 03/13/08	
Main Product: PCBA, DS91M047EVK, ROHS						

Notes:

DO NOT STUFF:

U2

M1-10

JP3,4,5,6

R1-15

T1-2,7,15,17,19,21,23,3,11,12,16,18,20,22,24

J3,4

C5,7,8,9,10

SMA13-22

REVISION RECORD			
LTR:	ECO NO:	APPROVED:	DATE:
0	INITIAL RELEASE		

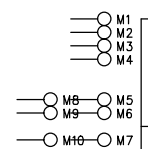
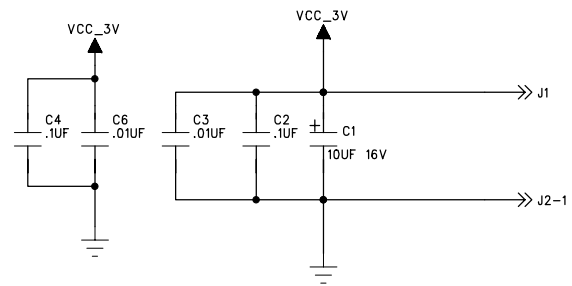
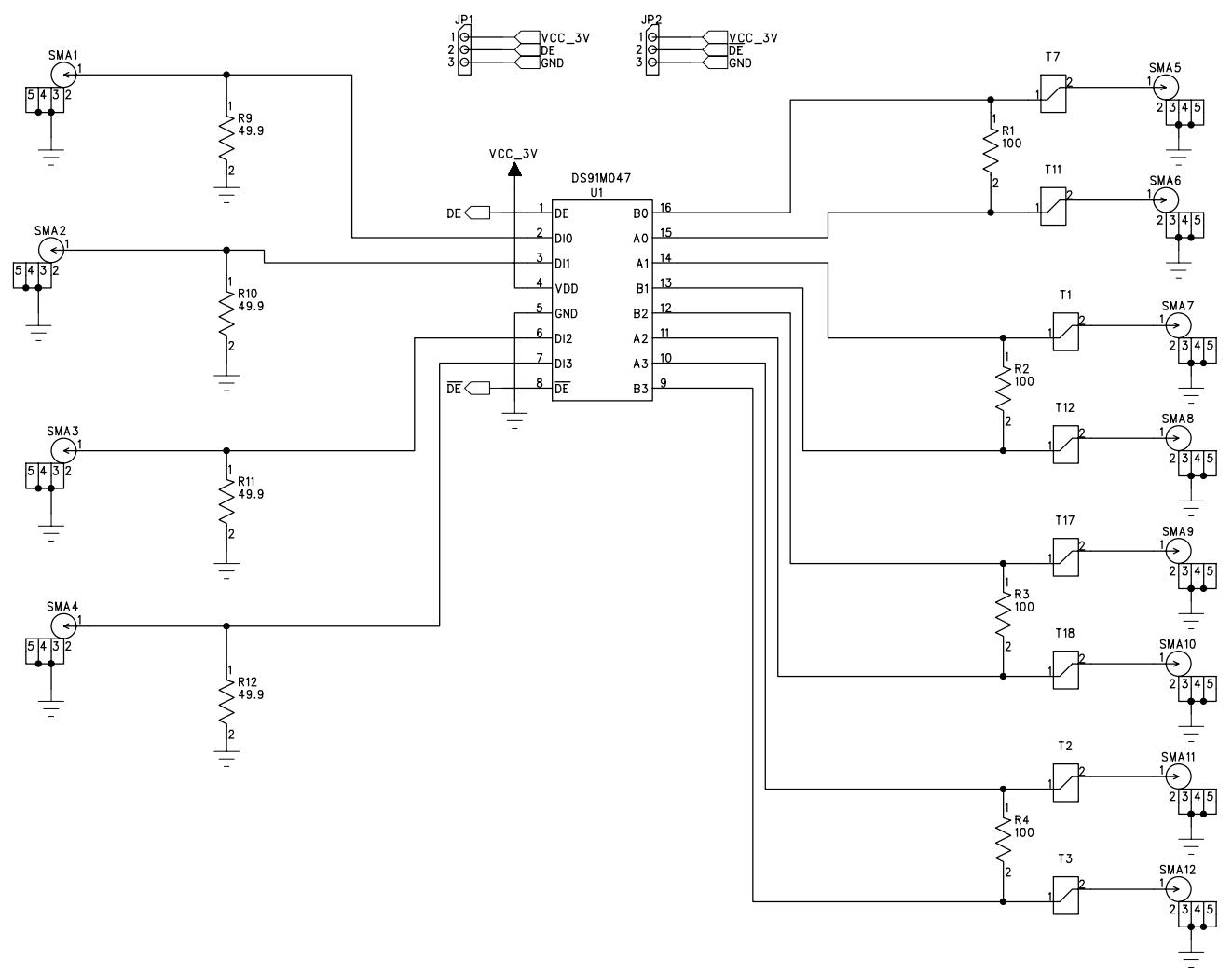

 25 NorthBrook Drive
 Gray, Maine 04039
 U.S.A.
 DRAWN: ACF DATED: 3/11/08

COMPANY: NATIONAL SEMICONDUCTOR			
TITLE: SCHEMATIC DS91M047EVK/DS91M124EVK/DS91M125EVK			
CODE:	SIZE: C	DRAWING NO: S-06539	REV: 0
SCALE:		SHEET: 1 OF 2	

D

D

C

C

B

B

A

A

6

5

4

3

2

1

REVISION RECORD			
LTR:	ECO NO:	APPROVED:	DATE:
0	INITIAL RELEASE		

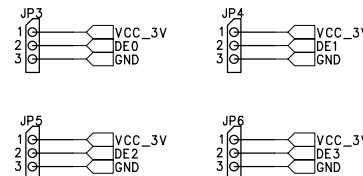
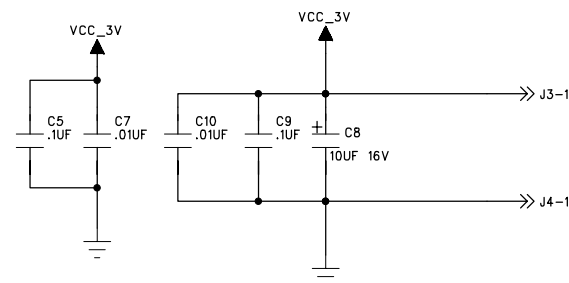
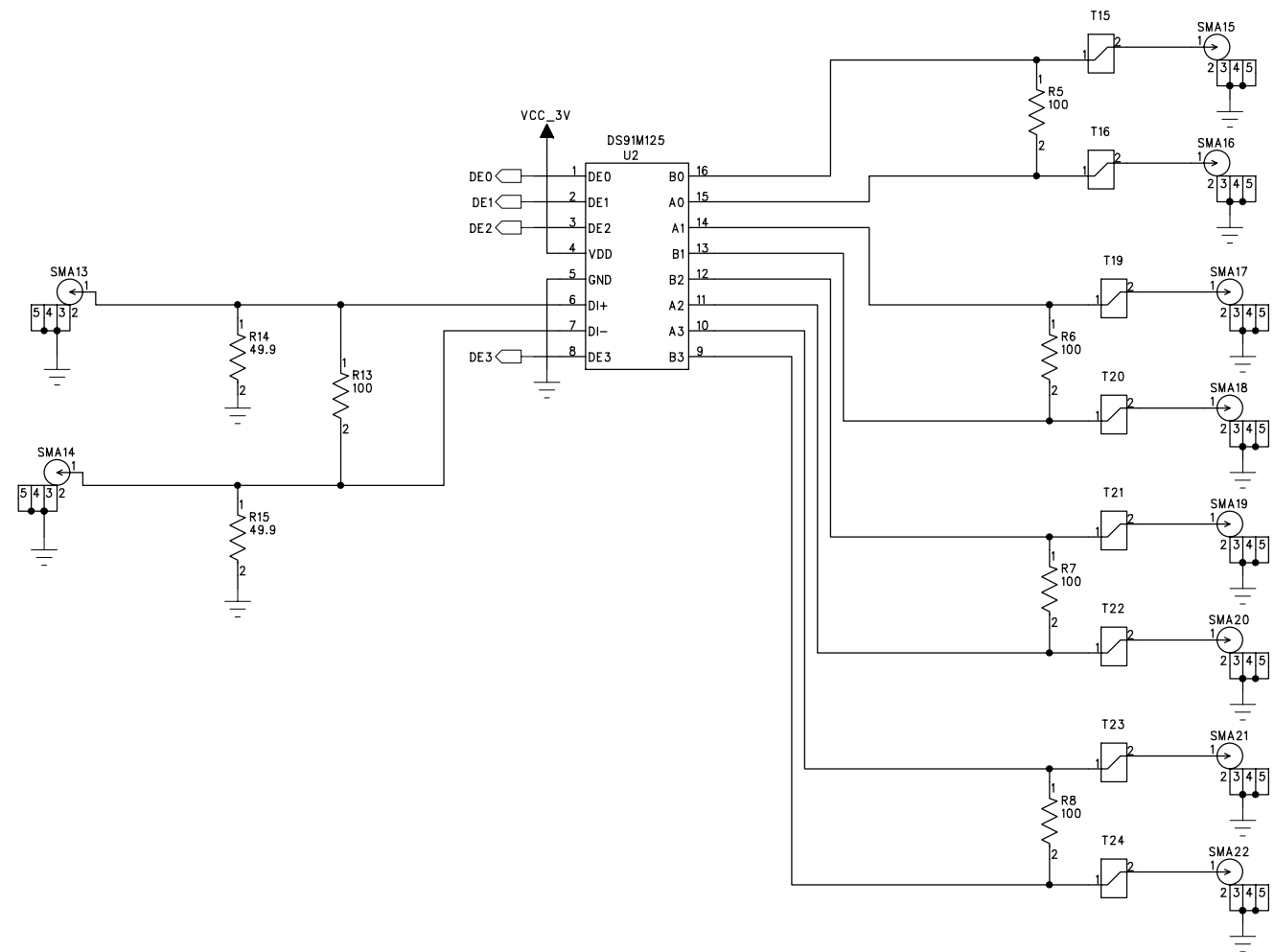

COMPANY:	NATIONAL SEMICONDUCTOR		
TITLE:	SCHEMATIC DS91M047EVK/DS91M124EVK/DS91M125EVK		

 25 NorthBrook Drive Gray, Maine 04039 U.S.A.	CODE:	SIZE:	DRAWING NO:	REV:
		C	S-6539	0
DRAWN: ACF	DATED: 3/11/08	SCALE:		SHEET: 2 OF 2

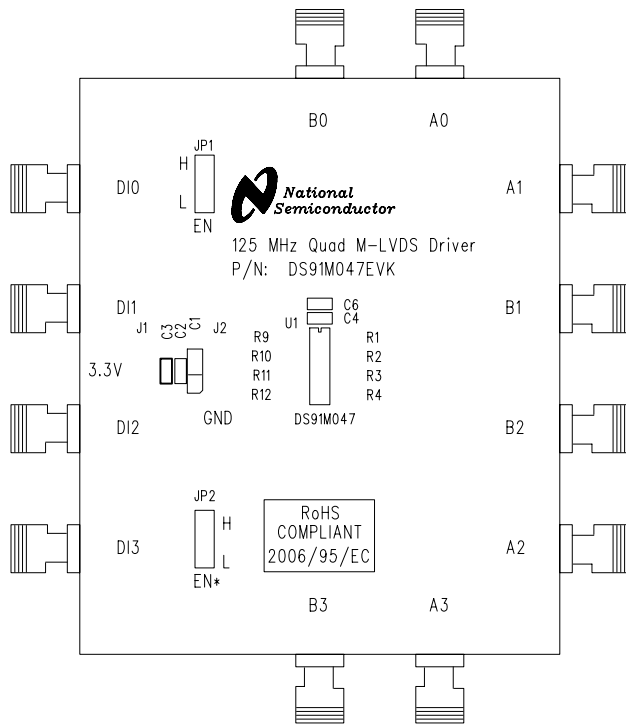

- SILKSCREEN TOP

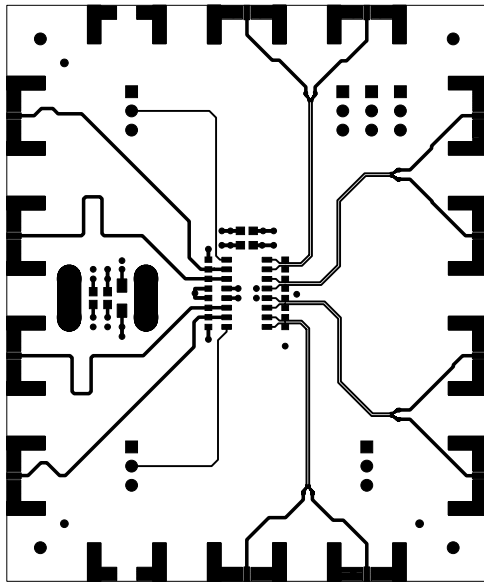

-
TOP

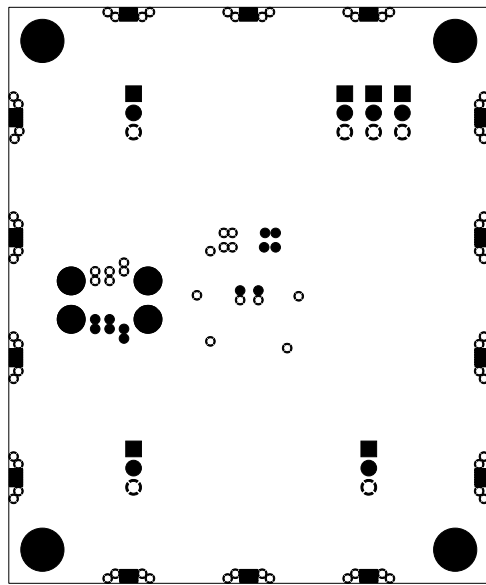

-
LAYER 2

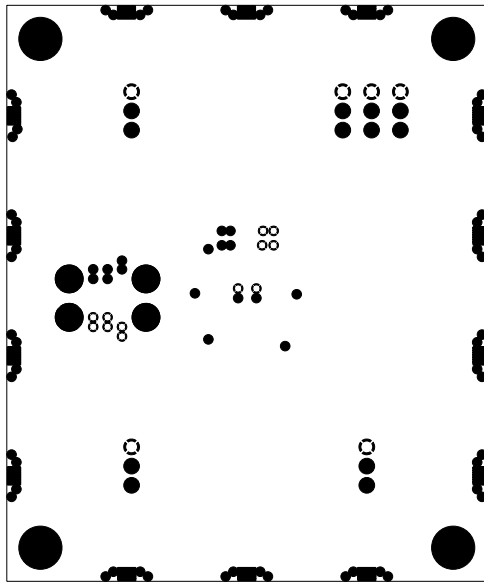

LAYER 3

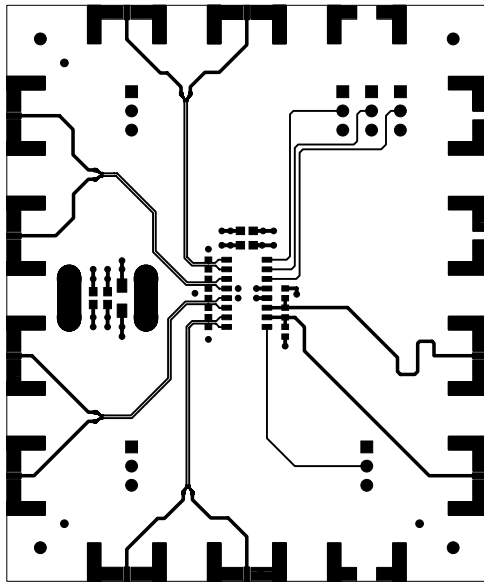

BOTTOM

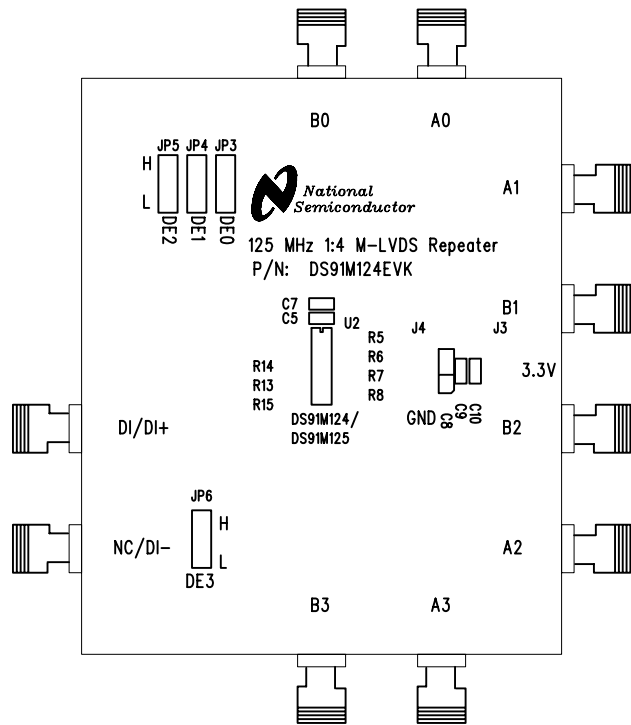

SILKSCREEN BOTTOM

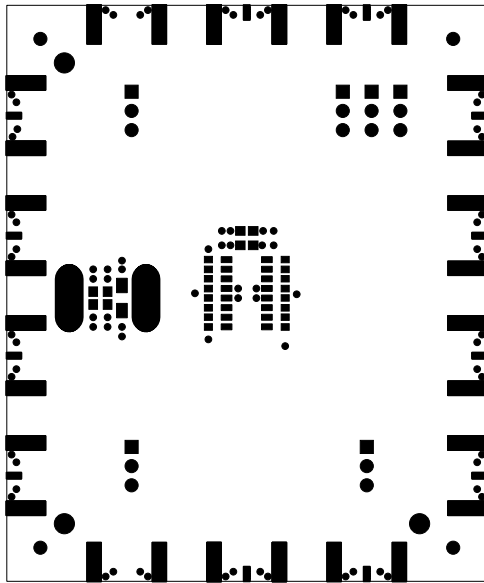

-
SOLDERMASK TOP

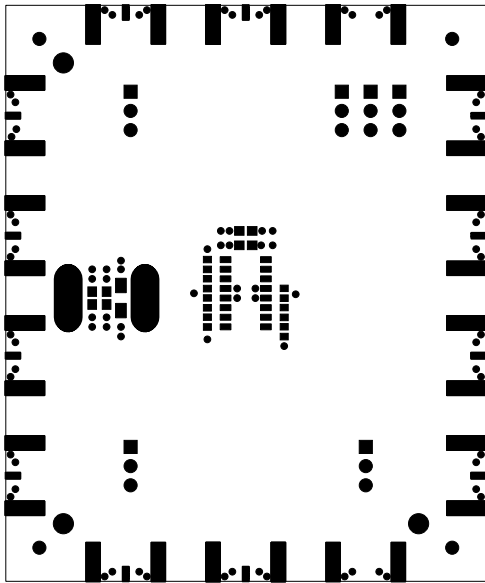

20LDERMA3K BOTL0M

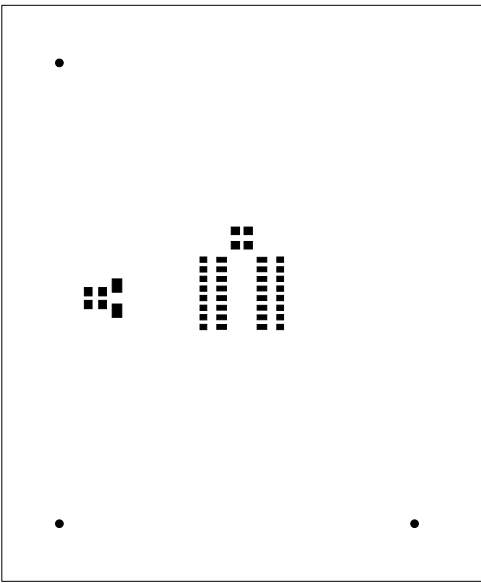

-
SOLDERPASTE TOP
SQUEEGEE VIEW

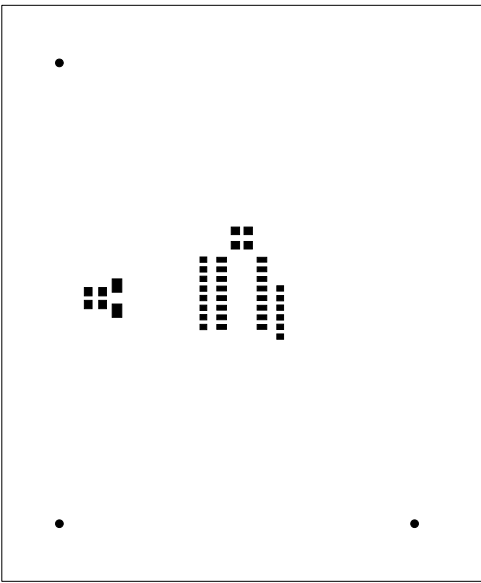

SOLDERPASTE BOTTOM