

Use Video Standards for Eye-Opening Data Transmission: Mega-bits @ Many Meters

James A. Mears

National Semiconductor

Wireless and Broadband System Design Conference

Abstract

Adopting existing video standards and devices benefits long-haul data transmission. Error-free data transmission over hundreds of meters is easily accomplished on coax or twisted pair. Techniques and devices supporting The Society of Motion Picture and Television Engineers (SMPTE) digital video standards can implement a wide variety of data transmission tasks in telecommunications and computers. These standards provide engineers well-defined, comprehensive and available solutions for reliable data transmission. Added benefits are the inter-operability, stability and longevity afforded designs using these standards and devices. Readily available components build links operating to 400Mbps and 300meters on existing coax systems. These provide eye-opening performance while delivering mega-bits @ many meters.

Author/Speaker

James A. Mears

Current Activities

James Mears is a Member of the Technical Staff in National Semiconductor's Interface Products Group working in application development for National's Serial Digital Video and Interface products. He is the creator of National's popular Transmission Line and Serial Digital and Interface RAPIDESIGNER© sliderules for engineers.

Background

James received his BSEE in 1970 from Louisiana Polytechnic Institute. His experience includes the design and construction of broadcast television production facilities, HF/DF antenna systems, RF test equipment, computer and communication systems, electric motors and drive systems, audio equipment and instrumentation, and semiconductors. He joined Fairchild Semiconductor in 1981 and National Semiconductor through its subsequent acquisition of Fairchild. James has held several positions in Applications Engineering and Management. He is also an accomplished technical author, residential architect and composer of liturgical music.

The Challenges of Digital Television

Television broadcasting is undergoing the most sweeping technological change since the advent of colour broadcasting or videotape. The changes are world-wide and are being driven both by governmental mandate and a desire to improve TV broadcast quality across all transmission mediums. Digital data transmission of TV video improves picture and sound quality and uniformity by converting the analog picture colour (chrominance), brightness (luminance) and audio to precise digital representations. Theoretically, these digital representations can be transmitted, stored and recorded countless times without degradation—something not possible with analog signals. However, making theory a reality presents many serious technological challenges.

The conversion to digital video signals brings with it higher data transport rates and wider bandwidth requirements than for analog video. Digital TV video is transmitted serially at 270Mbps for standard definition pictures, 360Mbps for wide-screen standard definition pictures and 1.485Gbps for high-definition pictures. These rates can be handled by the installed base of existing cabling and connector technologies. This is not an insignificant consideration, since cabling and connection devices are often the largest and single most costly system in TV plant facilities. Large TV studios sometimes house tens or even hundreds of thousands of kilometers of precision 75Ω coaxial cable. So, its replacement would present a major, if not insurmountable, cost impact to the conversion to digital signalling. Nevertheless, much of the other signal processing and transmission equipment must be replaced with types designed to handle higher data rate digital signals.

The SMPTE Digital Television Standards: Your guides for the long-haul

The Society of Motion Picture and Television Engineers (SMPTE), the standards organization for film and television broadcasting, has developed standards covering all aspects of digital TV video signal handling processes and equipment. The SMPTE standards, which are also ANSI recognized standards, assure that adequate capability, compatibility and inter-operability are maintained for signals, equipment and media used in digital TV video applications. The SMPTE standards offer a comprehensive set of proven techniques and equipment specifications for handling digital video data. And while the SMPTE standards may not be as familiar as other data communications standards, they can be applied to many other types of wide-band data processing and transport. This is happening with the

support of manufacturers who offer readily available products designed around the SMPTE digital TV video standards for data processing and transmission. Long-haul data and telecommunications are two industries which are rapidly adopting and adapting the SMPTE digital video standards for their data transport needs. In fact, several ITU (formerly known as CCITT) standards are virtually identical to corresponding SMPTE standards.

Adoption of existing SMPTE standards offers the user numerous benefits including:

- A global, democratic standardization process,
- International recognition and use,
- Technical adequacy, stability and longevity,
- Uniformity and commonality,
- Economic stability, and
- Wide equipment and product support.

The standards cover every aspect of the signal handling process: interface, electrical and mechanical. Testing and test methods are also covered in the relevant standard or in documents of recommended practices denoted by RP in the document number. Representative of the essential layers covered by the standards are:

- Protocol layer: data manipulation, control and processing,
- Data layer: formats and coding, synchronization, ancillary data, Error Detection and Handling (EDH), machine control, embedded data (audio),
- Transport layer: moving data, signal standards, equipment standards, I/O standards, cables and connectors.

Every aspect is clearly defined in the standard, ready to use as-is, and represents comprehensive, sensible and system-oriented thinking.

Applicable SMPTE Standards

Those SMPTE standards that can be almost universally adopted and applied with little or no modification are:

- ANSI/SMPTE 259M-1997: 10-Bit 4:2:2 Component and 4fsc Composite Digital Signals—Serial Digital Interface

This standard establishes the requirements for standard-definition serial digital video (SDV) data transmission. It is probably the most frequently referred-to of the SMPTE standards and the major one of concern in this paper. The standard covers: signal characteristics and bit rates, connectors and cable, channel coding, transmission bit order and measurement methods. The data rates covered are 270 and 360Mbps at 10-bits precision.

Though many standards for serial data transport exist, SMPTE 259M is especially well thought out and supported by a variety of off-the-shelf products.

- ANSI/SMPTE 125M-1995: Component Video Signal 4:2:2—Bit-Parallel Digital Interface

Within signal origination and reception equipment, signals are more often processed in parallel form. This standard covers all aspects, interface, electrical and mechanical, for dealing with parallel data transmission at a 27MHz clock rate.

- ANSI/SMPTE 267M-1995: Bit-Parallel Digital Interface—Component Video Signal 4:2:2 16×9 Aspect Ratio

Similar to 125M, this standard applies to parallel data transmission at a 27 or 36MHz clock rate. Data is 10-bit precision.

- SMPTE 291M-1998: Ancilliary Data Packet and Space Formatting

Since almost 25% of the complete digital picture data space (space formerly occupied by synchronizing elements of the converted analog picture) is available for carrying data other than picture data, this standard describes the requirements for organizing and controlling this so-called ancilliary data. Normally, this space carries audio and error-checking data, but may also be used to transport a variety of other data types.

- SMPTE 292M (Proposed): Bit-Serial Digital Interface for High-Definition Television Systems

High-definition pictures require much more data and, consequently, higher data rates for transport, 1.485 Gbps being common. This standard is to High-Definition SDV what 259M is to Standard-Definition.

- SMPTE RP 165-1994: Error Detection Checkwords and Status Flags for Use in Bit-Serial Digital Interfaces for Television

Digital video transmission does not use on-the-fly error correction. Instead, error detection is done within video processing equipment and the check words appended in the ancilliary data space. System maintenance and control equipment monitor these Error Detection and Handling (EDH) checkwords. This permits maintenance personnel to determine failure points in the system and take corrective action.

Transmission Mediums

- Coaxial cable

The most common transmission medium for SDV is precision 75Ω coaxial cable. Belden 8281 is a common

example. This cable is widely used for analog video and has the largest installed base. The coaxial cable is probably the single most costly system in a broadcast plant. Many network production complexes have over a million kilometers of such cable installed. Replacement is not an issue when converting to digital video—the coax will remain and be used.

Despite being the industry workhorse for analog video transmissions for many years, coaxial cable is not without problems as a transmission medium for wide-band digital signals. It has significant attenuation with increasing frequency as the graph below shows. Several semiconductor manufacturers offer drivers and active cable equalizers for SDV which compensate the cable's attenuation. The capabilities of one such cable equalizer will be featured later.

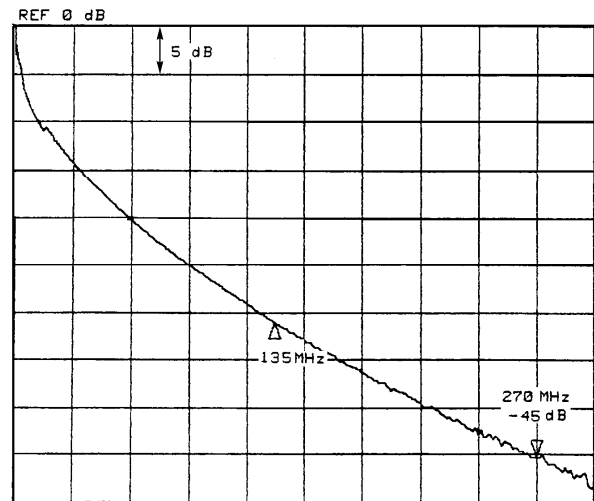

Coaxial Cable Attenuation Versus Frequency

- Twisted pair cables

When lower performance at lower cost can do the job twisted pair cables (TWP) can be used for shorter distances, about half that of coaxial cable. In existing installations TWP can add ancilliary paths at lower cost than coax. Twisted pair cable is frequently used in telecom and other applications. Some of its more advanced forms such as Category-5 are capable of good performance in high data rate SDV applications. For convenience, most of the integrated circuit drivers and receivers designed for SDV applications have differential input and output capability.

- Optical fibre cable

Still comparatively expensive for general use, optical fibre cables are used in critical applications where coaxial cable is inadequate or offers excessive vulnerability to the signals. Many new installations are using op-

tical fibre cable in anticipation of upgrading to high-definition video's wider bandwidth requirements. More products are becoming available that support optical fiber communications.

The SDV Data Transmission Path

A much simplified SDV data path is shown below. Here, SMPTE 125M parallel component data within a camera, for instance, is encoded, serialized and transmitted over coaxial cable to an SDV processing and routing system then on to a storage device such as a video editing system, tape recorder or still-store.

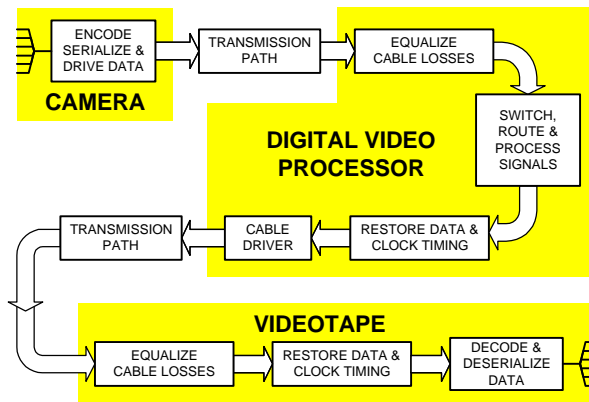

Generalized SDV Data Path

The receiver equalizes cable losses restoring the received signal to standard level (800mV_{p-p}). The signal is routed to an output channel where the SDV signal's bit- and clock timing are restored. The corrected data is sent via a cable driver and more coaxial cable to destination equipment, a videotape recorder (VTR) in this case. The received SDV data is again equalized, its timing is restored; and it is finally deserialized and decoded into its original parallel format.

SMPTE 259M SDV Demonstration System

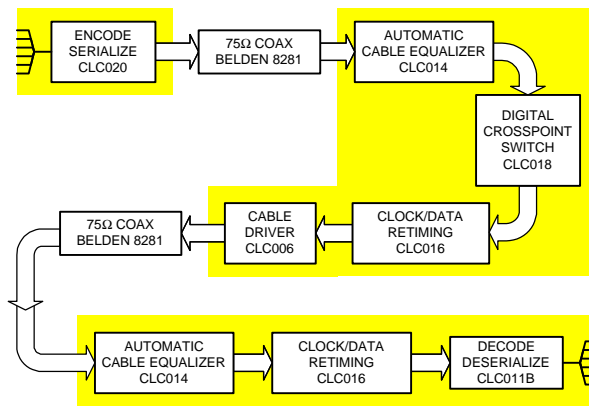

The Demonstration System

Replacing the more general SDV data path elements with actual devices, a system was built to demonstrate the capabilities of the SMPTE standards and compliant devices to effectively transport SDV data. Following a brief explanation of the function of each device, the system's performance, measurements of signal quality and device performance are presented.

Digital Video Encoder

The CLC020 is an integrated circuit SMPTE 259M SDV encoder with integrated cable driver. It encodes, serializes and transmits bit-parallel data conforming to SMPTE 125M and SMPTE 267M component video and SMPTE 244M composite video standards. It can also serialize general 8 or 10-bit parallel data. The CLC020 accepts parallel clock frequencies in the range from below 10MHz to over 40MHz. It outputs serial data at rates from below 100Mbps to over 400Mbps. An internal phase-locked loop (PLL) generates the serial data clock frequency. The PLL requires no external frequency setting, trimming or filtering components. Power consumption from a single 5-Volt supply is less than 250mW including two 75Ω back-matched output loads.

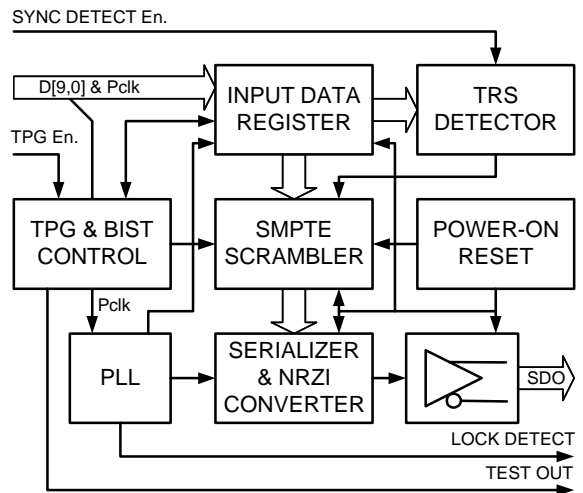

CLC020 SDV Encoder With Integral Cable Driver

Functions performed by the CLC020 include:

- parallel-to-serial data conversion,
- SMPTE polynomial (X^9+X^4+1) data encoding,
- NRZ to NRZI data format conversion,
- video test pattern generation and self-testing,
- serial clock generation and encoding with the serial data, and
- coaxial cable driving.

Input for sync (TRS) detection disabling and a PLL lock detect indicator output are provided.

Of particular interest, the CLC020 has an exclusive built-in self-test (BIST) and video test pattern generator (TPG) with four component video test patterns: reference black, PLL and equalizer pathologicals and modified colour bars. (Pathological data patterns are used as stress-testing functions in SDV systems). Test patterns are available in 4:3 and 16:9 raster sizes and both NTSC and PAL formats. Separate power pins for the output driver, PLL and the digital logic improve power supply rejection, jitter and noise performance.

A companion device, the CLC021 adds EDH generation and insertion, and the capability to independently control each of the sub-functions of the device.

Cable Drivers

Traditionally, analog video has used ECL-like signal levels for transmission medium compatibility and reduced noise performance. SMPTE 259M SDV systems likewise use AC-coupling with ECL signal levels of $800\text{mV}_{\text{p-p}} \pm 10\%$ into the cables. The driver circuits usually employ back-match (series) termination resistors to mitigate the effects of mis-terminated receivers. External load or pull-down resistors (usually 150Ω) are required for proper operation of these drivers. These voltage-mode drivers must supply $1.6\text{V}_{\text{p-p}}$ into the load network to achieve correct cable signal levels. Standing current consumption is high, 91mW average per output.

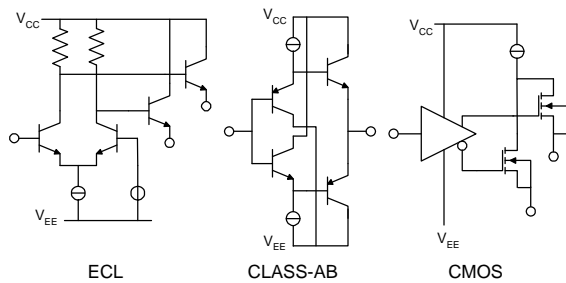

SDV Driver Output Types

National's Comlinear SDV cable drivers CLC006 and CLC007 use a push-pull class-AB output stage for better signal quality and reduced static power. This output produces $1.6\text{V}_{\text{p-p}}$ levels into back-matched 75Ω loads but requires no external pull-down resistor. This eliminates standing current and reduces system power. Outputs on these drivers are also differential.

The driver used on the all-CMOS CLC020 and CLC021 SDV encoders deserves special mention. These devices use a newly developed current-mode driver shown here

in simplified schematic. Like ECL, this driver uses an external resistor to establish the correct drive voltage for the cable. However, this resistor serves both as the back-matching and output generator resistance-setting function. Since the resistor value is that of the cable's impedance, the output voltage produced by the driver is just $800\text{mV}_{\text{p-p}}$. Together with the fact that there is no standing current in the current-mode output, this further reduces DC power consumption.

Cable Equalizer

Perhaps the single most important element in an SDV transmission system is the cable equalizer portion of the receive circuit. Recalling the attenuation characteristic of coaxial cable, the equalizer must supply 40dB of gain at 200MHz . Moreover its pass-band must be substantially wider than the highest data rate in order to correctly preserve pulse fidelity at maximum gain. And, it must not add jitter to the received signal.

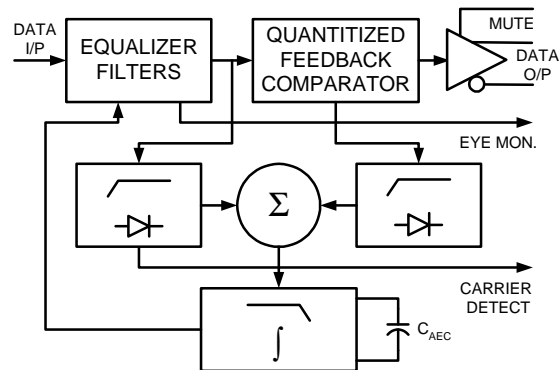

CLC014 Adaptive Cable Equalizer

The CLC014 adaptive cable equalizer automatically compensates for attenuation in coaxial cables (like 75Ω Belden 8281) with lengths from zero to 300meters or to 150meters for Category 5 UTP. Jitter performance is $180\text{ps}_{\text{p-p}}$ for 270Mbps data through 200meters of Belden 8281. This exceptional performance provides wide error margin in digital data links. To make signal quality monitoring easier, the CLC014 has an output for displaying its output signal eye-pattern. Output muting and carrier detect functions are also included.

Digital Crosspoint Switch

Television production and telecommunications facilities share much in common—both make use of large signal switching and routing systems. The TV router handles continuous streaming data, whereas, the telecommunications systems mostly packetized data. Nevertheless, similar digital switch components serve equally well in both applications.

The CLC018 digital crosspoint switch is a fully differential, 8x8, non-blocking architecture capable of operating at data rates to 1.5Gbps. With its multiplexer-based architecture, any input may be simultaneously connected to one or more outputs and any output may be connected to any input. Each output may also be placed independently in tri-state mode. This permits simple expansion to larger switch arrays.

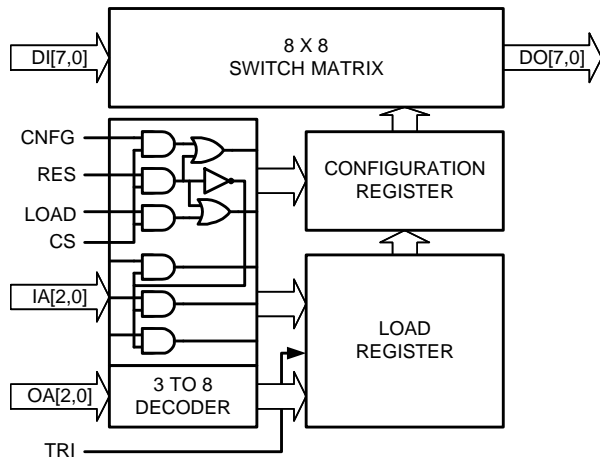

CLC018 Digital Crosspoint Switch

The CLC018 employs a double-row control signal latch architecture. This permits background switch array reprogramming and one-step configuration of the entire array. Two reset modes are provided: broadcast, where all outputs are connected to DIO, and tri-state, where all outputs are disabled. Output drivers are open collector and are ECL/PECL compatible. The CLC018 also features the ability to operate from single or split power supplies where the data paths operate from an ECL negative supply while the control logic operates from a CMOS positive supply.

Such switches must not contribute to signal jitter or crosstalk. The CLC018 has extremely low channel-to-channel crosstalk which contributes to its low all-hostile jitter performance of 50ps_{p-p}.

Data Retimer/Clock Separator

The serial data that has passed through the receiver and switching system suffers some degradation from jitter and duty-cycle distortion. A well-designed SDV processing system periodically cleans up and re-times the data. The CLC016 data retiming PLL performs this function. It processes the serial data, re-establishing proper bit widths and their correct relationship to the serial clock edges. It also serves as clock-data separator for the SDV data deserializing system.

For simplicity, the CLC016 has an automatic data rate selecting function. Up to four data rates between 40 and 400Mbps can be automatically set, each with a single resistor. Trimming, crystals or external oscillators are not required. The data rate may also be manually set.

A flexible filter function allows customizing PLL loop bandwidth. Low phase detector output offset and low VCO injection combine to insure that the CLC016 does not generate bit errors or large phase transients in response to extreme fluctuations in data transition density. This improves performance when handling the SDV pathological patterns.

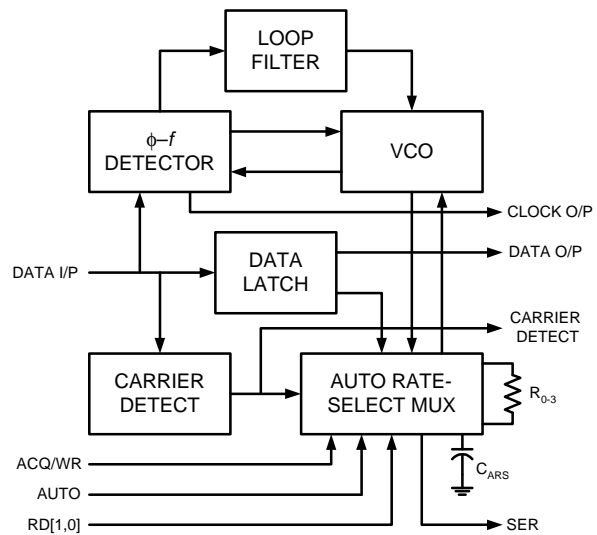

CLC016 Data Retimer/Clock Separator

The CLC016 has carrier detect and mute functions which, used together, automatically latch the outputs, thus preventing random transitions when no data is being received. The outputs are differential and open-collector for ECL/PECL compatibility.

Descrambler/Deserializer

The last, but not least, element of the SDV system is the descrambler (also called the decoder) and deserializer function. The CLC011B SDV decoder accepts serial data and a serial data-rate clock and outputs SMPTE standard parallel data with an accompanying word-rate clock. It restores the originally encoded parallel data by applying a reverse polynomial algorithm. Descrambled data is converted from NRZI to NRZ coding and the encoded parallel clock is extracted. The Timing Reference Signals (TRS), marking the start and end of active picture data, are decoded to identify the received word data boundaries. The outputs EAV (end of active video), NSP (new sync position) and TRS indicate the presence of the decoded TRS words.

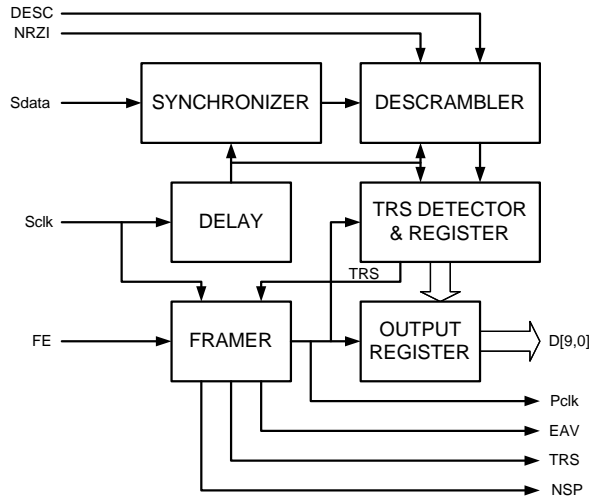

CLC011B Serial Digital Video Decoder

The CLC011B can be used to deserialize other 8 or 10-bit data. The descrambling, NRZI conversion and data framing functions may be independently disabled, thus tailoring it to any desired level of functionality. The CLC011B uses current-mode logic (CML) to reduce noise injection into the power supply. This eases board layout and interfacing considerations. The parallel data and clock outputs feature independent power supply pins allowing operation of the output drivers from the voltage supply of the logic system which it is driving.

System Performance

The SMPTE 259M demonstration system was constructed and tested in accordance with applicable SMPTE standards and test data. Tests presented here were made at the standard-definition data rate of 270Mbps. Standard SDV test equipment simplified the testing. The demonstration system is also capable of handling and has been tested to the as-yet non-standard wide-screen format data rate of 360Mbps. Highlights from the test results are presented here.

The CLC020 SDV encoder, operating in its Test Pattern Generator (TPG) mode, is the signal source. The test pattern for the tests is a modified SMPTE 75% saturation, 8-vertical colour bars pattern (not having chroma or luma dithering at bar transitions). This is the standard test pattern for most tests including jitter tests. The parallel clock source is derived from a Tektronix TG2000 Programmable TV Generator via a receiver system containing the CLC014 Cable Equalizer, CLC016 Data Retimer/Clock Separator and CLC011B Deserializer. The parallel clock for the CLC020 is from the CLC011B's output. This is a tougher test of the CLC020 since the clock will have acquired jitter from

the receiver system. The jitter from the receiver system measured about 0.1UI (about 370ps_{p-p}). A unit interval (UI) at 270Mbps is about 3.7ns. The CLC020 signal source should not add to this jitter level.

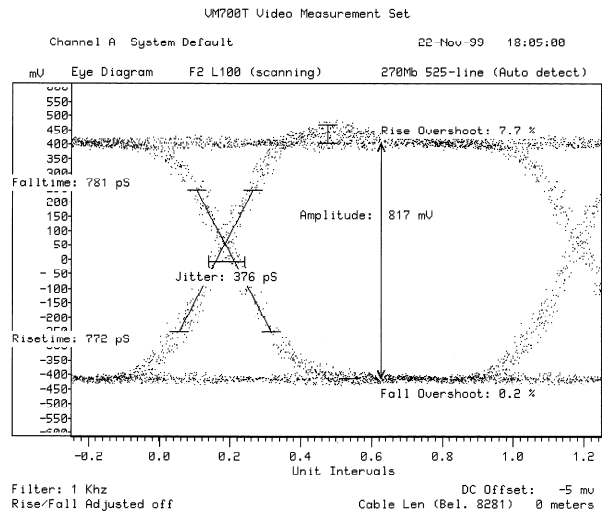

CLC020 Output (SMPTE Colour Bars)

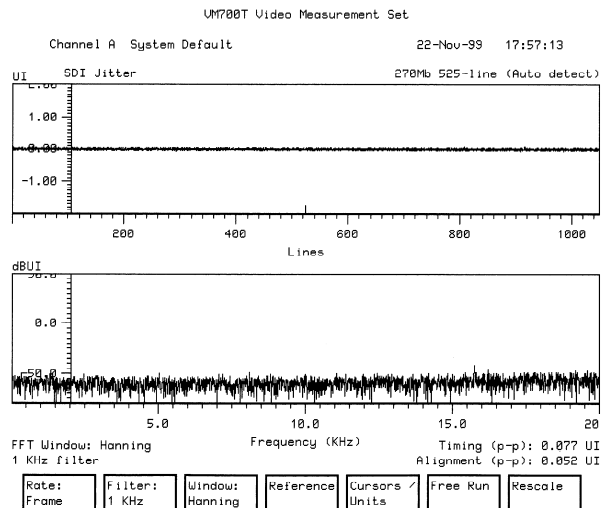

CLC020 Output Jitter (SMPTE Colour Bars)

In fact, the CLC020 encoder reduces the jitter present in the reference clock source. Wideband output jitter (1kHz filter bandwidth) from the CLC020 measures about 0.077UI (285ps_{p-p}). Alignment is 0.052UI (193ps_{p-p}).

Shown next are some measurements of the source signal after it has passed through 150m and 300m of Bel-den 8281, 75Ω coaxial cable.

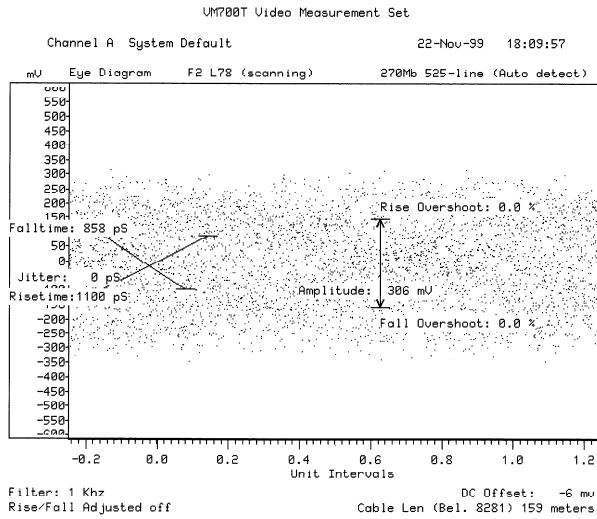

CLC020 Output after 150m of Belden 8281

After passing through 150m of cable (160m according to the measurement system), signal amplitude has fallen to about 300mV and any semblance to a useable signal has vanished.

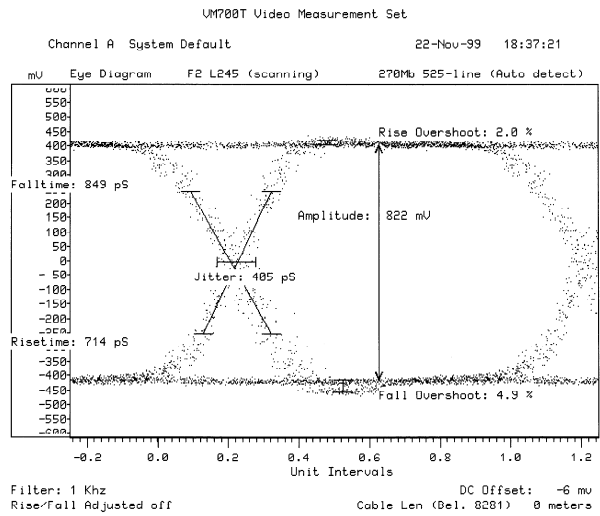

CLC014 Cable Equalizer Output
(CLC020 source with 1m cable)

For reference, the output of the CLC014 Adaptive Cable Equalizer was measured receiving the source signal through 1m of cable. Total jitter here is about 0.11UI (405ps_{p-p}). This can be taken as the residual jitter present in the system without cable.

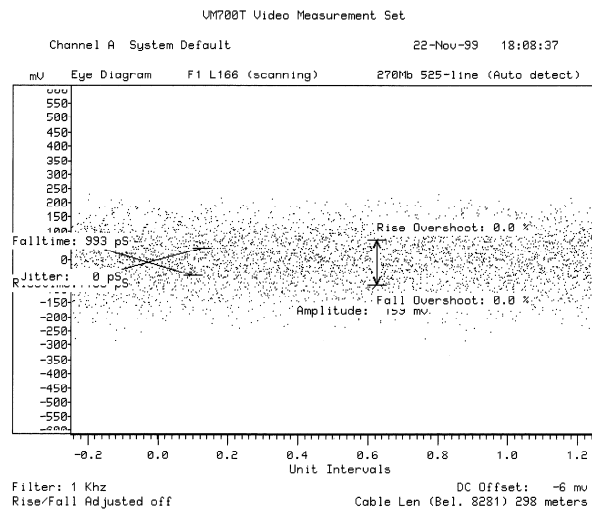

CLC020 Output after 300m of Belden 8281

After passing through 300m of cable, the amplitude is down to 160mV and the signal appears to be just noise. Can a useable signal be recovered after it passes through either 150m or 300m? The answer is: yes.

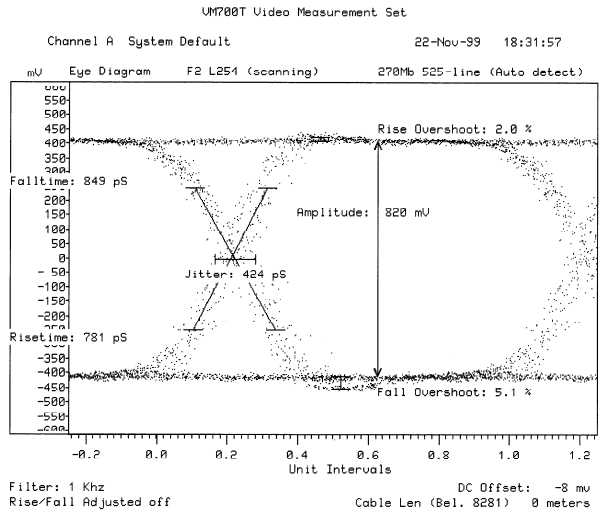

CLC014 Cable Equalizer Output
(CLC020 source with 150m of Belden 8281)

Even after 150m, the signal is recovered by the CLC014 Adaptive Cable Equalizer. This is a very useable signal. Total jitter here is about 0.115UI (424ps_{p-p}).

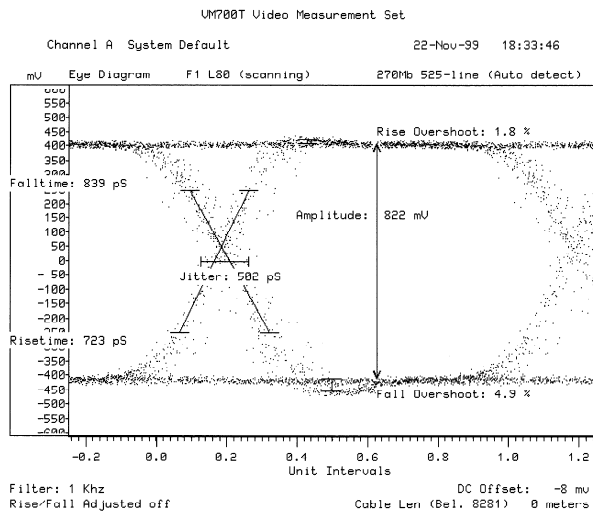

CLC014 Cable Equalizer Output
(CLC020 source with 300m of Belden 8281)

Even after 300m of cable, the CLC014 can recover a useable signal. Here is the signal after recovery. Jitter is only 0.135UI (502ps_{p-p}) and well within the limit of 0.2UI. Note that there is no degradation in either period or risetimes relative to the system with 1m cable.

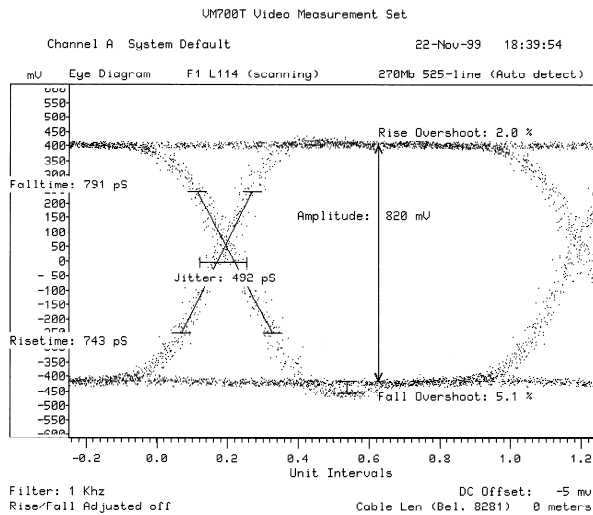

CLC016 Data Retimer Output
(CLC020 source with 1m cable)

The signal is now put through routing and is retimed by the CLC016. For the system and 1m cable, there is no discernable difference when compared to the signal just out of the CLC014 cable equalizer.

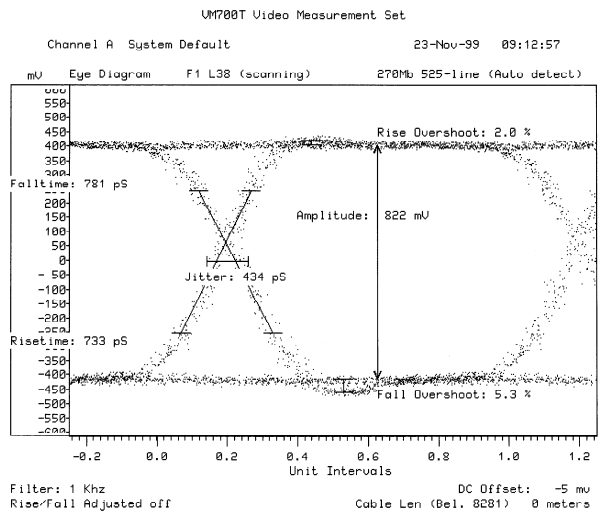

CLC016 Data Retimer Output
(CLC020 source with 150m cable)

Shown above is the retimed output with 150m cable. Note that there is little difference from a 1m cable.

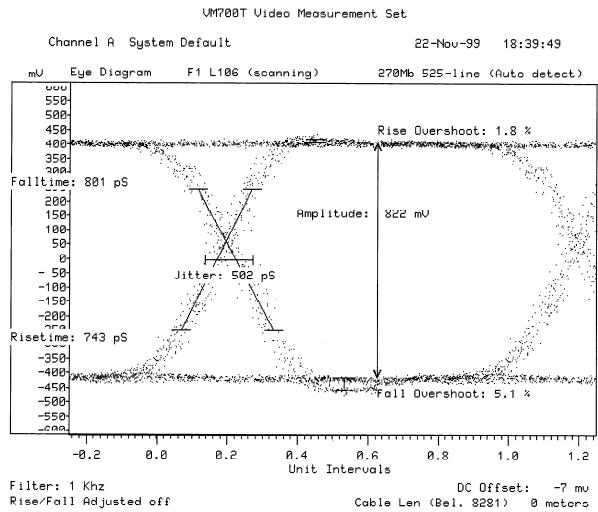

CLC016 Data Retimer Output
(CLC020 source with 300m cable)

Lastly, here is the retimed output with the 300m cable. There is no practical difference in the quality of this signal when compared to the signal through 1m of cable. Clearly, this shows the power of systems and devices built from components which comply with the SMPTE digital video standards to handle signals even under adverse conditions.

Testing SMPTE SDV Systems

Testing SMPTE SDV systems does not need to be difficult. Readily available TV or datalink test equipment can be used as is the norm for other types of digital data transport systems.

Techniques such as those described in SMPTE RP 165 (EDH) can provide on-line maintenance tools to track not just errored data but error sources in the system.

Devices like the CLC020 and CLC021 SDV encoders have built-in self-test and test pattern generation capabilities which ease device and in-system testing. In addition, other test devices such as EDH co-processors are available. Future devices from National will continue to feature such built-in test and monitoring capabilities. This will become essential with the advent of high-definition television SDV data transmission devices and systems operating at 1.485Gbps.

Conclusions

SMPTE video standards and compliant devices offer comprehensive solutions to high data-rate signal transmission for many applications. Systems based on the SMPTE standards are easily implemented using readily available, proven products from many manufacturers. These systems and products have established a record of reliability, ease of use and performance virtually unmatched by other transmission standards and are in use today throughout the world. SMPTE standard-based systems offer compatibility with other related data transmission standards using the same hardware. Designs based on these standards are cost effective compared to proprietary device-based approaches. These systems are testable and maintainable offering end users economy, longevity and stability.

SMPTE standards-based digital data transmission systems do achieve eye-opening performance, delivering mega-bits @ many meters.

Recommended Resources

Society of Motion Picture and Television Engineers
595 West Hartsdale Avenue
White Plains, New York 10607-1824
www.smpte.org
Tel: (914) 761-1100
FAX: (914) 761-3115

Glossary

ANSI—American National Standards Institute: the US standards representative to the International Standards Organization (ISO).

component signal—A colour video signal where separate signals represent the picture aspects, for example: RGB or YIQ.

composite signal—A colour video signal where all picture information is multiplexed into one signal.

ECL—Emitter-coupled logic: logic and digital signal interface using emitter-followers.

EDH—Error Detection and Handling: a recommended practice for identifying and logging errors in bit-serial television interfaces (SMPTE 259M); reference SMPTE RP 165-1994.

NTSC—National Television Systems Committee: developmental body for US colour TV broadcast method adopted by the FCC in 1953.

PAL—Phase-alternating line: colour correction system most commonly used in European analog colour TV broadcasting.

PECL—Pseudo emitter-coupled logic: logic and digital signal interface using emitter-followers or emitter-follower work-alikes and operating (usually) from positive TTL-type power supplies.

SDV—Serial Digital Video: video data as carried over bit-serial interfaces (SMPTE 259M).

TRS—Timing reference signal: digital synchronization method used as a timing element in digital picture data. Equivalent to synchronization pulses in analog video.

UI—Unit Interval: the time duration of a data bit or cell.

4:2:2—Sampling method for digital component video signals in which the luminance signal is sampled at 13.5MHz and each of the chrominance (colour-difference) signals at 6.75MHz..

4fsc—Sampling method for digital composite video in which sampling is done at 4× the colour subcarrier frequency (14.3MHz for NTSC or 17.7MHz for PAL).

Suggested Bibliography

Digital Television Fundamentals, Michael Robin and Michel Poulin, McGraw-Hill, 1998, ISBN 0-07-053168-4

DTV: The Revolution in Electronic Imaging, Jerry Whitaker, McGraw-Hill, 1998, ISBN 0-07-0069626-8

Video Engineering, Arch Luther and Andrew Inglis, McGraw-Hill, 1999, ISBN 0-07-135017-9

Wire, Cable, and Fiber Optics for Video & Audio Engineers, Stephen H. Lampen, McGraw-Hill, 1998, ISBN 0-07-038134-8

Digital Image and Audio Communications, Stanley N. Baron and Mark I. Krivocheev, 1996, Van Nostrand Reinhold, ISBN 0-442-02106-2

“Transmission Line Characteristics”, AN-108, Bill Fowler, National Semiconductor

“Data Transmission Lines and Their Characteristics”, AN-806, Kenneth M. True, National Semiconductor

“Reflections: Computations and Waveforms”, AN-807, Kenneth M. True, National Semiconductor

“Long Transmission Lines and Data Signal Quality”, AN-808, Kenneth M. True, National Semiconductor

“Common Data Transmission Parameters and their Definitions”, AN-912, John Goldie, National Semiconductor

“A Practical Guide To Cable Selection”, AN-916, David Hess and John Goldie, National Semiconductor

Serial Digital Video & Interface Rapidesigner© (Sliderule calculator), Document 633202-001, Jim Mears, National Semiconductor

“Serial Digital Video & Interface Rapidesigner© Operation and Applications Guide”, AN-1113, James A. Mears, National Semiconductor

Transmission Line Rapidesigner© (Sliderule calculator), Document 633201-001, Jim Mears, National Semiconductor

“Transmission Line Rapidesigner© Operation and Applications Guide”, AN-905, James A. Mears, National Semiconductor