



# LM4935 Evaluation Package Instructions v1.3

*National Semiconductor Audio*

## Table of Contents

Evaluation Package Contents.....	3
Software Installation Instructions.....	3
LM4935 Control Software.....	3
Hardware Installation Instructions.....	3
Powering up the LM4935 Demoboard.....	4
S/PDIF Receiver Operation.....	6
Interfacing with the LM4935 Digital Audio I/O.....	7
DC Volume Control.....	8
Headphone Output Configuration.....	9
High-Efficiency Loudspeaker Evaluation.....	10
3.5mm and 2.5mm Audio Jacks.....	11

## Evaluation Package Contents:

LM4935 Demoboard  
USB Interface Card  
USB Cable  
LM4935 Control Software

## Software Installation Instructions (Windows 2000/NT/XP):

- 1) Unzip the LM4935 Setup 1\_2.zip file to a specified folder.
- 2) Run setup.exe from the specified folder.
- 3) The LM4935 Control Software installation will begin.
- 4) Please refer to the readme.txt for further information.

## LM4935 Control Software:

- 1) The LM4935 Control Software will operate only if the LM4935 Demoboard setup has been properly powered up and connected to the PC's USB port.
- 2) If there is no proper connection made, the LM4935 Control Software will not operate correctly.
- 3) If the LM4935 Demoboard setup is correct and the LM4935 control software loads normally, and then either the USB or power is disconnected, the LM4935 Control Software will indicate that there is a USB I/O error and will freeze up. Once the proper connection (USB or Power) has been re-established then the LM4935 Control Software will operate normally.
- 4) For more detail please refer to the LM4935 Control Software readme.txt file.

## Hardware Installation Instructions:

- 1) Plug the USB Interface Card to the bottom side of the LM4935 Demoboard. The connection between the USB Interface Card and the LM4935 Demoboard is keyed in a way such that there is only one possible physical orientation between the two boards.
- 2) Attach one end of the USB cable to a free USB port on your PC and the other end to the USB Interface Card.
- 3) Run the LM4935.exe file. The LM4935 Control Software will run only if a proper USB connection exists from the PC to the demoboard and also if there is power supplied to the demoboard (see next section).

## Powering up the LM4935 Demoboard:

- 1) The LM4935 Demoboard can be powered up through the USB Interface Card or through an external power supply.
- 2) Switch Y1 sets USB Power operation (USB POW) or External Power supply operation (EXT POW).

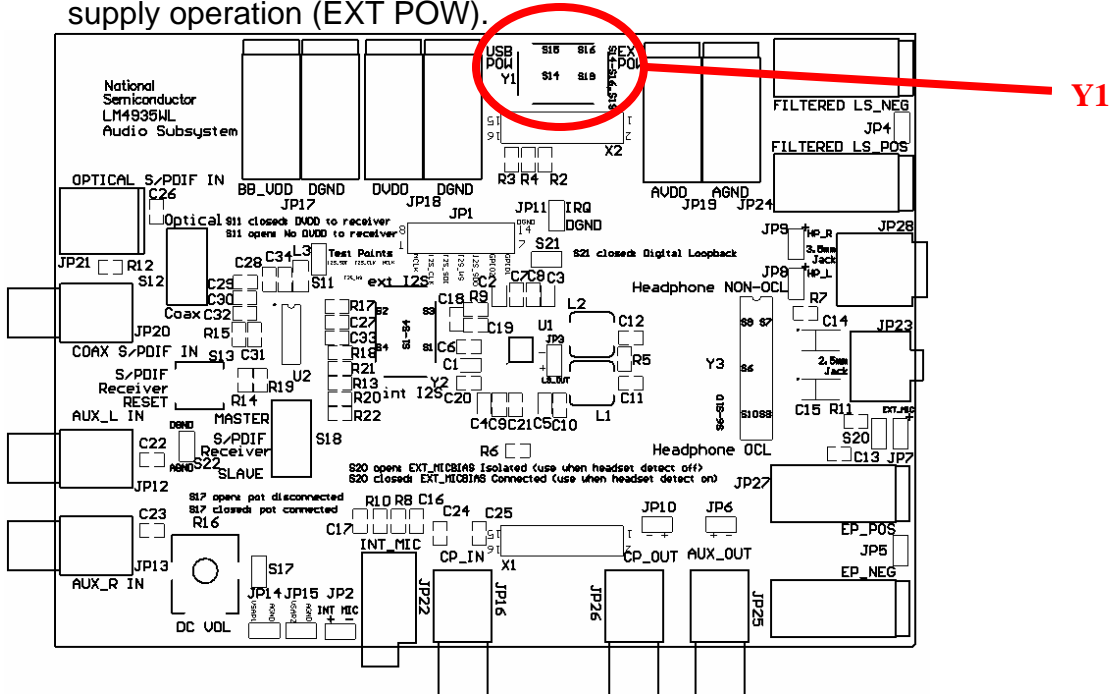

**Fig. 1 Powering up the LM4935 Demoboard**

- 3) When setting switch Y1 for USB Power operation, please make sure that all external power supply lines are disconnected from the banana connectors of the LM4935 Demoboard. When configured for USB Power operation, the LM4935 Demoboard does not require any external power supplies, as the LM4935 Demoboard draws its required power from the USB port.
- 4) During USB Power operation, DVDD and BBVDD is set to 3.3V. AVDD is set according to the position of the J1 jumper on the USB Interface Card. Placing the J1 jumper at the “5V” position will set AVDD to 5V. Placing the J1 jumper at the “ADJ” position sets AVDD to be either 3.8V or 3V depending on the LM4935 Control Software setting (default setting is 3.8V).
- 5) Jumper S11 shorts the digital power supply pin of the onboard CS8416 S/PDIF receiver to system DVDD of the LM4935 Demoboard. If there is an S/PDIF digital audio source available, then S11 must be closed to provide power to the S/PDIF receiver. S11 should be left open whenever the CS8416 is not needed, as this will isolate the LM4935 from the CS8416.

S11

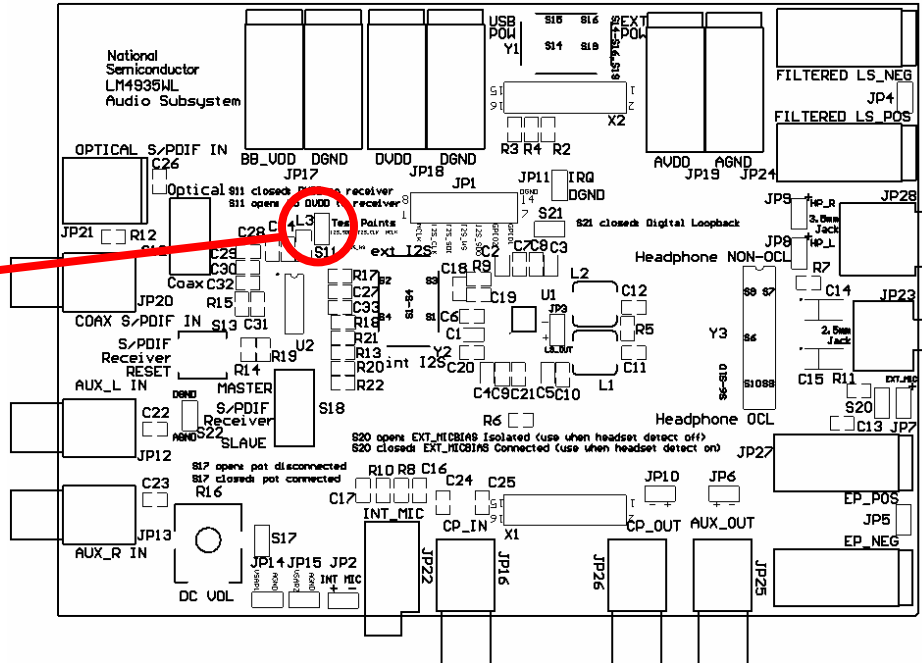
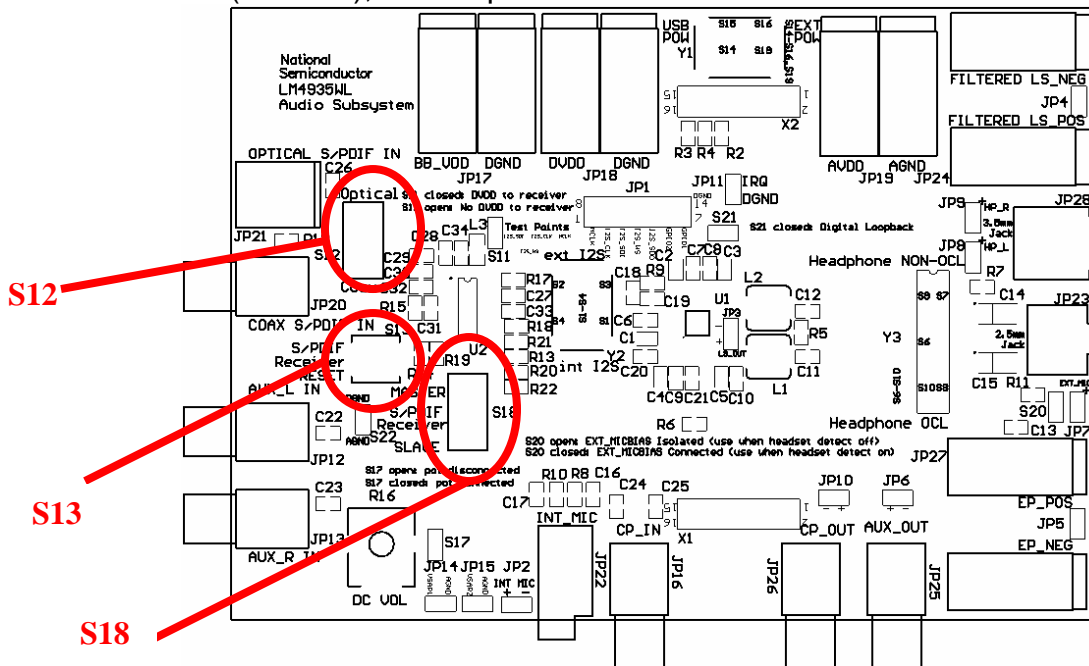

**Fig. 2 Powering up the S/PDIF Receiver**

- 6) During External Power supply operation, the use of external power supplies is expected. There are dedicated banana jack inputs for BBVDD, DVDD, AVDD, AGND, and DGND located on the top of the demoboard to accommodate external power supply inputs. It is recommended to keep  $AVDD \geq DVDD$ . Please refer to the LM4935 datasheet for operating ranges.
- 7) On the LM4935 demoboard, the  $A\_VDD$  and  $LS\_VDD$  pins are tied to system AVDD. The  $PLL\_VDD$  and  $D\_VDD$  pins are tied to system DVDD.

## S/PDIF Receiver Operation:

- 1) The CS8416 S/PDIF Receiver will only operate if DVDD or the voltage applied to the CS8416's digital power supply pin (via bottom pin of S11) is set between 3V to 3.6V.
- 2) After device power up, to ensure that the CS8416 has initialized correctly, it is recommended to RESET the CS8416. To RESET the CS8416, press and release the S13 button. RESET is also recommended after toggling between the MASTER/SLAVE operation of the S/PDIF receiver. A CS8416 RESET can help in instances whenever there is no audio output while using the S/PDIF audio input.
- 3) Set the position of switch S18 to toggle between the MASTER/SLAVE operation of the CS8416 S/PDIF receiver. To run the CS8416 as MASTER, set S18 to the "S/PDIF Receiver MASTER" position. To run the CS8416 as SLAVE, set S18 to the "S/PDIF Receiver SLAVE" position. MASTER/SLAVE operation of the LM4935 is set through the Interface Tab of the LM4935 Control Software. If the CS8416 is set to MASTER, then the LM4935 should be programmed to SLAVE, and vice versa.
- 4) The S/PDIF receiver can accept S/PDIF audio data through either an optical cable or digital coaxial cable. If using an optical cable, set the position of switch S12 to "OPTICAL". If using a digital coaxial cable (75 Ohm), set the position of S12 to "Coax".



## Interfacing with the LM4935's Digital Audio I/O:

- 1) The LM4935 can accept digital audio data from either the CS8416 S/PDIF receiver or from an external digital audio data source (such as the Audio Precision PSIA-2722).
- 2) Setting switch Y2 to the "int I2S" position connects the outputs of the CS8416 to the digital audio I/O of the LM4935. In the "intI2S" position, MCLK is generated from the output of the CS8416 and routed to the MCLK input of the LM4935.
- 3) Setting switch Y2 to the "ext I2S" position connects the JP1 (7x2) connector to the LM4935's digital audio interface. JP1 is a universal connector that can accept digital audio data and clocks from an external source such as the PSIA-2722. In the "extI2S" position, MCLK is expected from an external source (via pin1 of JP1) and is routed to the MCLK input of the LM4935.
- 4) Please refer to the silkscreen of the LM4935 Demoboard's JP1 connector for the correct pinout. When using the "extI2S" switch setting, the CS8416 is not needed and therefore should be disconnected from the system power supply by opening S11

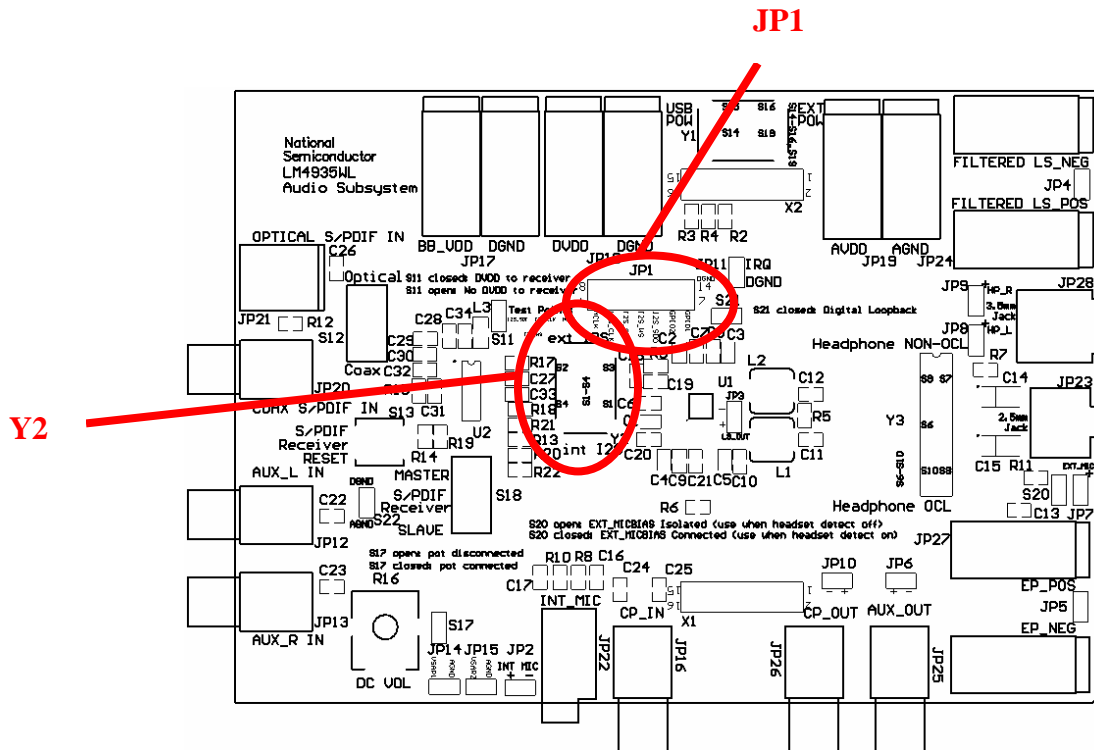

**Fig. 4 Interfacing with the LM4935's Digital Audio I/O**

## DC Volume Control:

- 1) Using the LM4935 Control Software, the user can select between implementing I2C/SPI volume control or DC Volume control. When using the DC Volume control, jumper S17 should be shorted. S17 connects the potentiometer to the VSAR1 input (JP14) of the LM4935. This allows the potentiometer to control the DC Volume of the LM4935.
- 2) Whenever an external voltage source is required to drive the VSAR1 input (JP14), it is recommended to open S17, to isolate the potentiometer from the system.

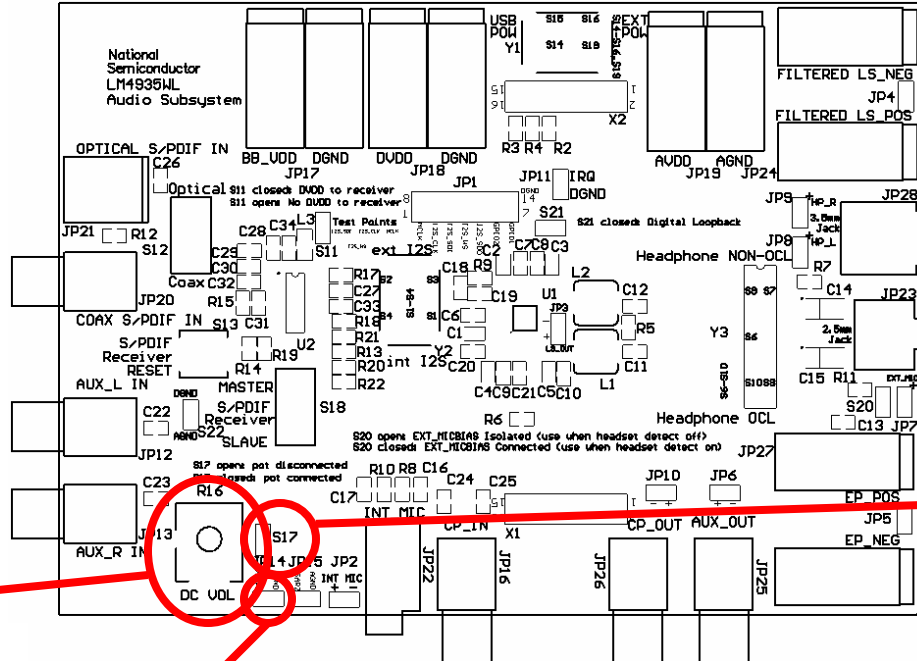

**Fig.5 DC Volume Control**

**Potentiometer**

**JP14**

**S17**

## Headphone Output Configuration:

- 1) The LM4935 Demoboard supports two different headphone output configurations: Output-Capacitorless (OCL) and Single-ended Capacitively Coupled (SE).
- 2) Switch Y3 is used to switch between OCL and SE headphone output modes. When Y3 is placed in the "Headphone OCL" position, the headphone outputs are wired for OCL operation. When Y3 is placed in the "Headphone NON-OCL" position, the headphone outputs are wired for SE operation.
- 3) The LM4935 Control Software programs the LM4935 to be either in OCL mode or SE mode. It is important to match the software setting to the position of switch Y3 on the LM4935 Demoboard for correct operation.

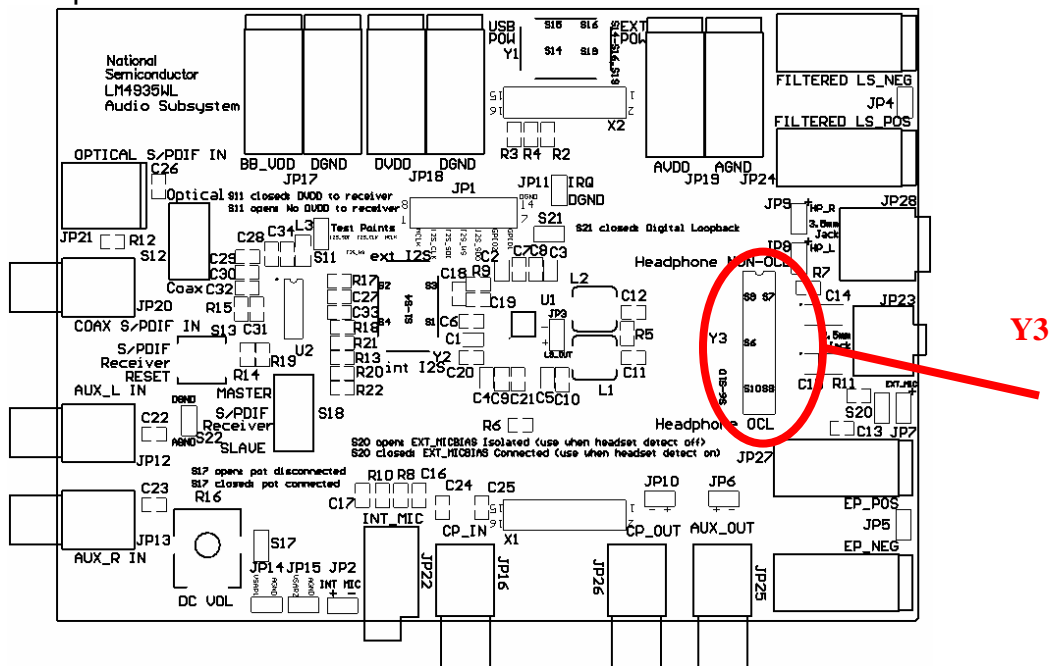

Fig. 6 Headphone Output Configuration

## High-Efficiency Loudspeaker Evaluation:

- 1) The LM4935 contains a filterless switching amplifier output designed to drive a mobile phone's handsfree loudspeaker.
- 2) Connector JP3 is used to directly access the switching amplifier's loudspeaker outputs. Connect any speaker load directly to JP3.
- 3) The LM4935 contains an LC measurement filter to filter out the switching artifacts of the switching amplifier outputs. This allows the user to analyze the loudspeaker's audio output signal without using any special external filters. The filtered loudspeaker audio output can be accessed through banana jacks JP24 or through header JP4.

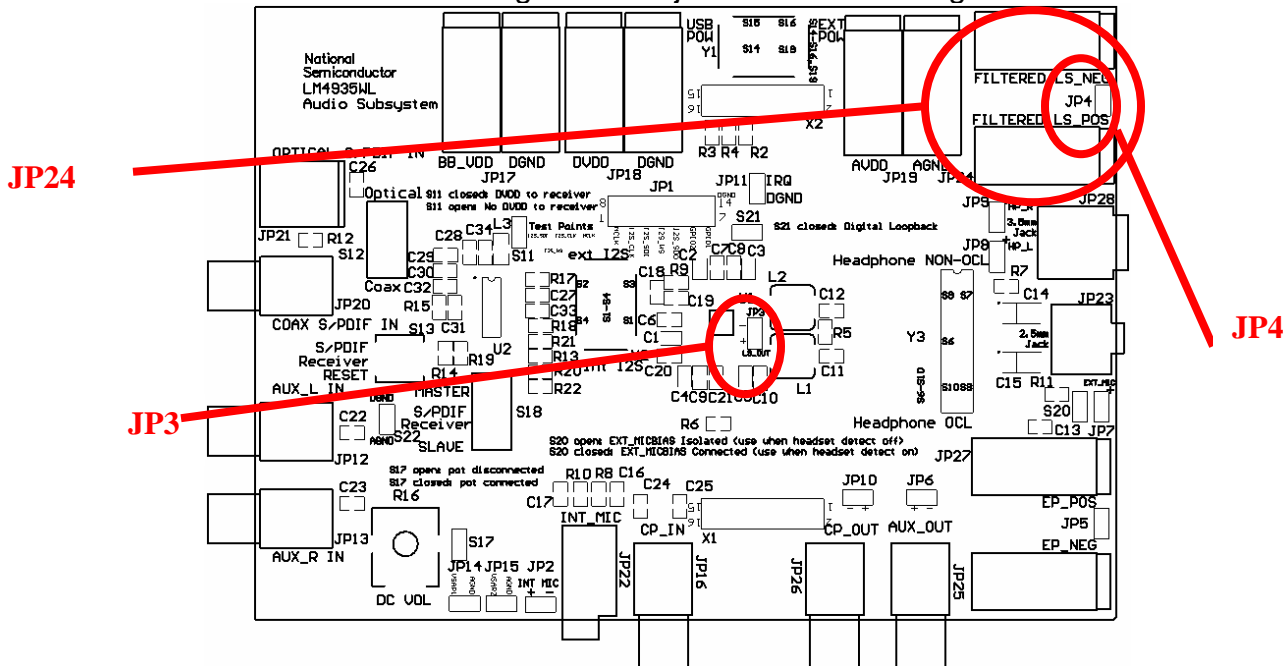
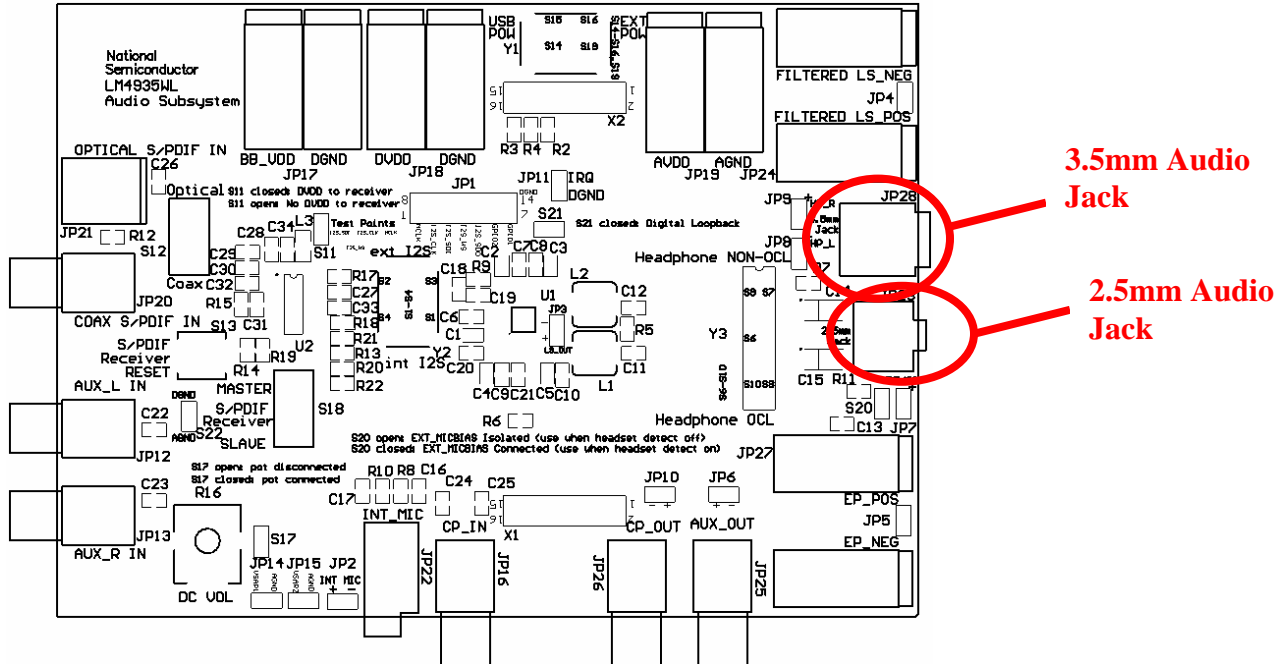

Fig. 7 High-Efficiency Loudspeaker Evaluation

### 3.5mm and 2.5mm Audio Jacks:

- 1) The LM4935 Demoboard can accommodate both 3.5mm and 2.5mm audio plugs with 3 or 4 wire type headphones/headsets.



**Fig. 8 3.5mm and 2.5mm Audio Jacks**