

Precision current sensing amps with $< 15 \mu\text{V}/^\circ\text{C}$ drift. GUARANTEED!

Only National guarantees TC_{VOS} by tri-temp testing each device

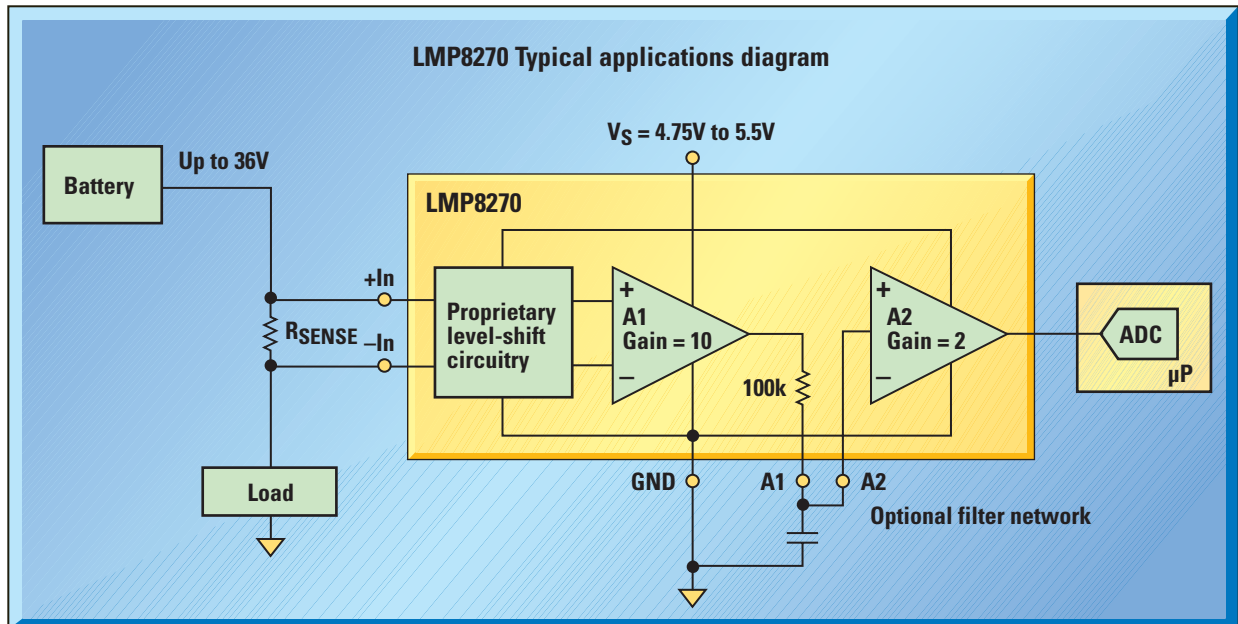

© National Semiconductor Corporation, 2005. National Semiconductor, \mathcal{N} and WEBENCH are registered trademarks and LMP is a trademark of National Semiconductor Corporation. All rights reserved.

LMP8270, LMP8271, and LMP8272 Features:

- Input offset voltage 1 mV max
- TC_{VOS} 15 $\mu\text{V}/^\circ\text{C}$ max
- CMRR 80 dB (min)
- Gain temp drift ± 25 ppm/ $^\circ\text{C}$
- Extended CMVR -2V to 36V
- Operating temperature range -40°C to 125°C ;
(bare die) -40°C to 150°C
- LMP8270/72 Gain of 20/14
- LMP8271 Bidirectional measurement
- Supply voltage 4.75V to 5.5V
- Supply current 1 mA
- Rail-to-rail output voltage swing
- Available in SOIC-8 packages

Ideal for use in automotive, industrial, medical, test and instrumentation, consumer PCs, and notebooks



For FREE samples, datasheets, and WEBENCH®
online design tools, contact us today at

amplifiers.national.com

Or call: 1-800-272-9959

Free CD-ROM data catalog available at: freecd.national.com

 **National**
Semiconductor
The Sight & Sound of Information

Looking for the perfect op amp?

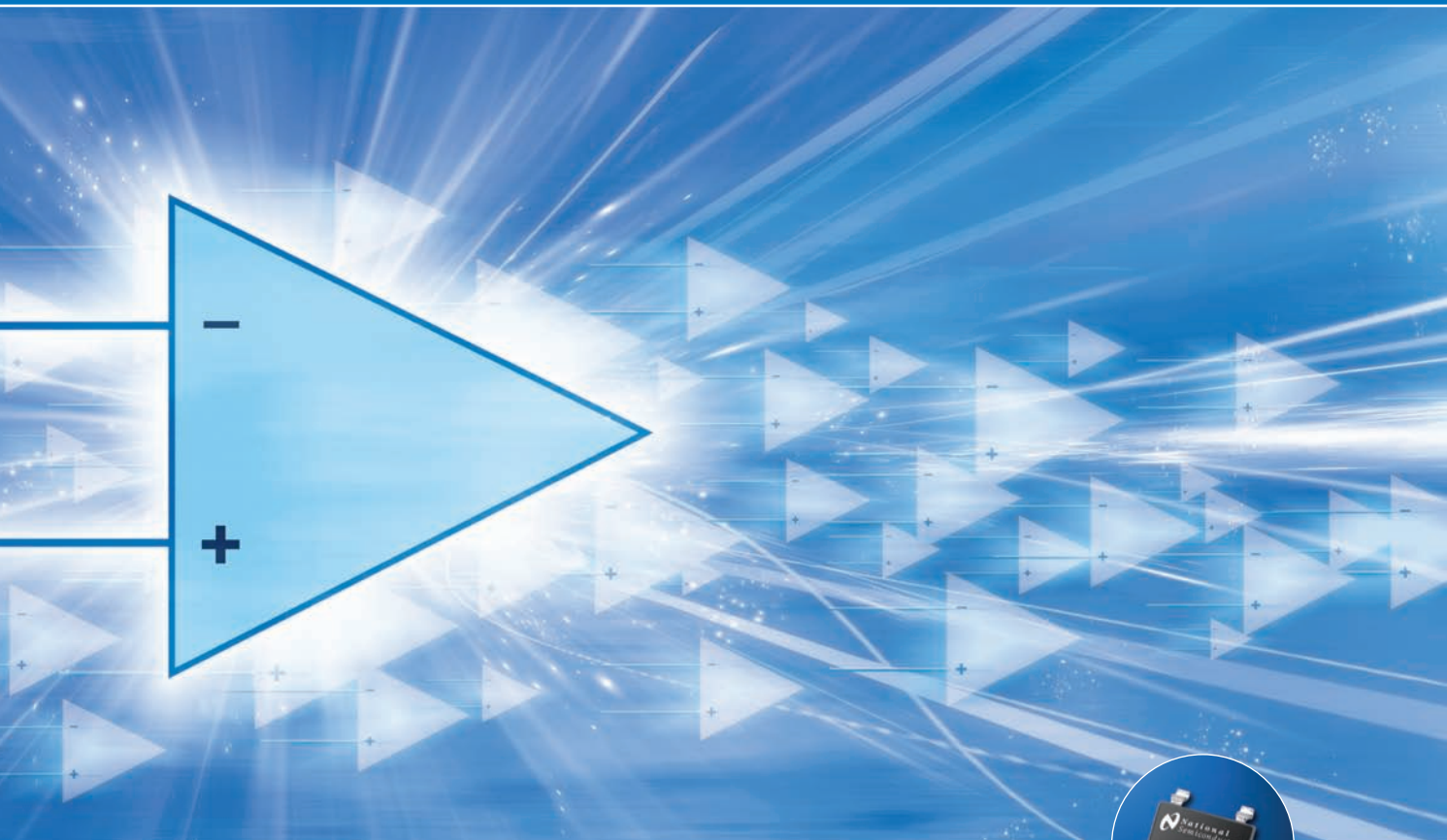

©National Semiconductor Corporation, 2005. National Semiconductor, , LMH, and WEBENCH are registered trademarks and Silicon Dust is a trademark of National Semiconductor Corporation. All rights reserved.



Search no further. National has the answers.

National Semiconductor wrote the book on amplifiers. Pioneers in the business, with innovations including the first low voltage op amp, National is THE expert when it comes to operational amplifiers. And the company continues to innovate and drive future technologies. Product offerings include complete op amp solutions from building-block products to application-specific standard products.

National's patented VIP10 process enables its LMH[®] amplifiers to be the highest speed and lowest power amplifiers in the market today.

National is also the leader in packaging technology—with innovations including the revolutionary Silicon Dust[™] and micro SMD packaging.

In addition to superior technology, National has tools to make analog design easy—such as WEBENCH[®] for amplifiers, National's newest online design tool. To learn more, visit amplifiers.national.com

 **National
Semiconductor**
The Sight & Sound of Information

BASICS

CURRENT MEASUREMENT *of Design*

Don Tuite, Analog/Power Editor

Take The Right Steps To Achieve Accurate Measurements

It Starts With Ohm's Law (Then It Gets Interesting)

Current measurements are used in a variety of equipment for control or safety functions. Measuring the voltage drop across a low-value resistor is the most common method of measuring the current flowing in a circuit (Fig. 1). The current flow through the load also flows through the R_{SENSE} resistor, also known as a shunt resistor, which creates a voltage drop, V_M , across the resistor.

Figure 1 depicts two current-measurement approaches. Ammeters were developed in the early history of electronics, and they're still used today. Typically, the meter itself may read full-scale when the current through it is 100 μA or 1 μA . So to read larger currents, it is connected in parallel with a resistor that shunts most of the current around the meter. That way, the meter can be scaled to measure any magnitude of current.

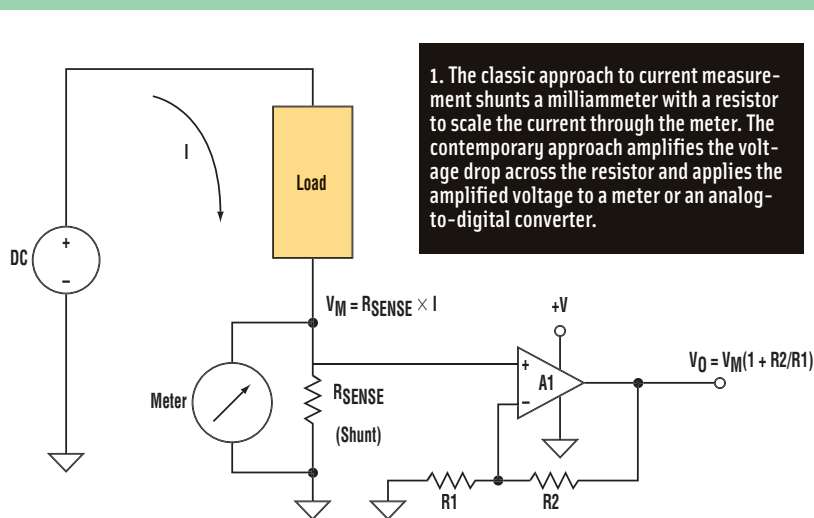

Resistor Sizing and Op-Amp Gain

A more contemporary approach for measuring current uses an operational amplifier, or op amp, to amplify the voltage dropped by the sense resistor. Often, the output is connected to an analog-to-digital converter (ADC). The first steps are to choose a value for the sense resistor and to set the amplifier's gain.

For example, suppose the current through the load varies from 0 to 10 A, and the ADC is designed for a maximum input signal of 5 V. Because the current is relatively high, a very low-value shunt resistor is required. To simplify calculations, choose 0.025 Ω. At the maximum current of 10 A, the voltage, V_M , across the shunt is $10 \times 0.025 = 250$ mV. The physical size of the shunt resistor is determined by the power dissipation, $P_d = I^2R$. Using the values from above, $P_d = 10^2 \times 0.025 = 2.5$ W. A power rating of 5 W or more should be used to minimize heat on the shunt resistor.

To satisfy the ADC's input requirements, the gain required by the amplifier is:

$$A_v = \frac{5.0v}{0.250v} = 20$$

If the signal from the shunt resistor is applied to the non-inverting input of the amplifier, gain A_v is one plus the ratio of the feedback and input resistors. Choosing a value of 5 kΩ for R_1 and a value of 95 kΩ for R_2 sets the gain to 20.

Consider Shunt Resistor Thermal Characteristics

The above example points to several areas that need additional consideration. The heating of the shunt resistor due to power dissipation or to ambient temperature changes affects the measurement accuracy by changing the resistance of the shunt. The various metals used in resistors offer different temperature coefficients (see the table).

Temperature Coefficients Of Metals Used In Resistors

Material	Resistivity ρ	Temperature coefficient α
Copper	1.7×10^{-6} Ω-cm	0.004041
Nickel	7.8×10^{-6} Ω-cm	0.005866
Platinum	10×10^{-6} Ω-cm	0.003729
Manganin	44×10^{-6} Ω-cm	0.000015
Nichrome	110×10^{-6} Ω-cm	0.00017

LMP™ amplifiers deliver high precision over time and temperature

New extended temperature range, no 1/f noise, single/dual/quad precision amplifier family

LMP2011, LMP2012, and LMP2014 features:

- Low guaranteed offset voltage over temperature (40 μV)
- Very low input offset voltage drift (0.015 $\mu\text{V}/^\circ\text{C}$)
- Extended operating temperature range from -40°C to 125°C
- Slew rate (4 $\text{V}/\mu\text{s}$)
- Wide gain-bandwidth product (3 MHz)
- No 1/f noise
- High open-loop voltage gain (130 dB)
- High CMRR (130 dB) and PSRR (120 dB)
- Low supply current (0.930 mA)
- LMP2011 is available in space-saving SOT23-5 and SOIC-8 packages
- LMP2012 is available in a MSOP-8 package
- LMP2014 is available in TSSOP-14 and LLP-14 packages

Ideal for use in medical, industrial, test and measurement, scales and weigh stations, automotive, PC, and telecommunications applications.





Reality TV for analog designers.
Tune in today at:
www.national.com/bobpeaseshow

Also-be sure to check out WEBENCH® for amplifiers
our new online design environment.

For FREE samples, datasheets, and more information on the
LMP2011/12/14, contact us today at amplifiers.national.com

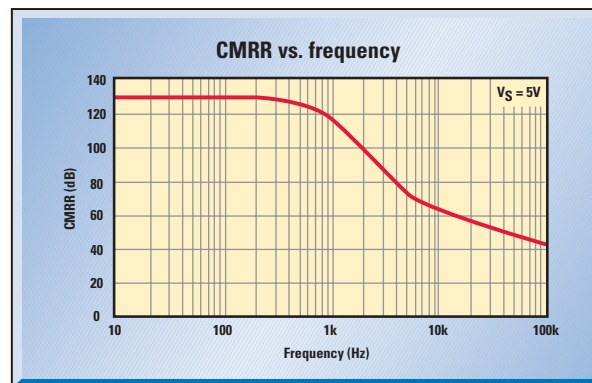
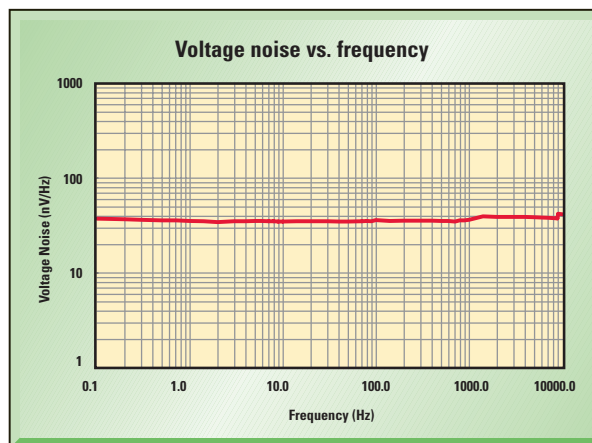
Or call: 1-800-272-9959



© National Semiconductor Corporation, 2004. National Semiconductor, , LLP, and WEBENCH are registered trademarks of National Semiconductor Corporation. Amplifiers Made Simple is a service mark of National Semiconductor Corporation. All rights reserved.

 **National
Semiconductor**
The Sight & Sound of Information

Kelvin Sense Resistors

A second area of concern is the connection between the shunt resistor and the amplifier's input. In the example we've been using, an ordinary 5-W resistor would have 20-gauge copper leads. Assume the leads are trimmed to 0.5 in. on either side of the resistor and soldered in place. Twenty-gauge copper wire has a resistance of about 0.001 Ω /in., which represents a 4% error, relative to the resistor's nominal value.

To avoid introducing such an error, two additional features are needed: a Kelvin connection to the shunt resistor and a differential-input amplifier. A Kelvin connection is a four-wire connection with two force leads and two sense leads (Fig. 2). Two of the wires (W1 and W2) are force leads, and they connect the shunt resistor to the high-current side of the circuit. The other two wires (W3 and W4) are sense leads, and they connect the voltage across the shunt resistor to the amplifier. This arrangement separates the load-current-carrying wires from the measurement circuit. The voltage drops in W1 and W2 are removed from the measurement of the voltage across the shunt resistor. To take full advantage of the Kelvin connection, a differential amplifier, as in Figure 3, is necessary.

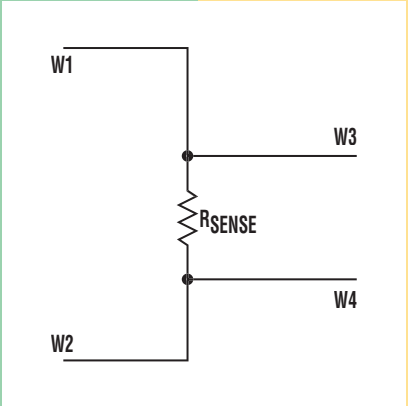

2. To avoid measurement errors caused by the voltage drops across conventional resistors' leads, Kelvin-connection sense resistors are supplied with four leads: two for the forcing current, and two others, connected right at the resistance element, for the high-impedance measurement circuit. Kelvin resistors come in a number of configurations.

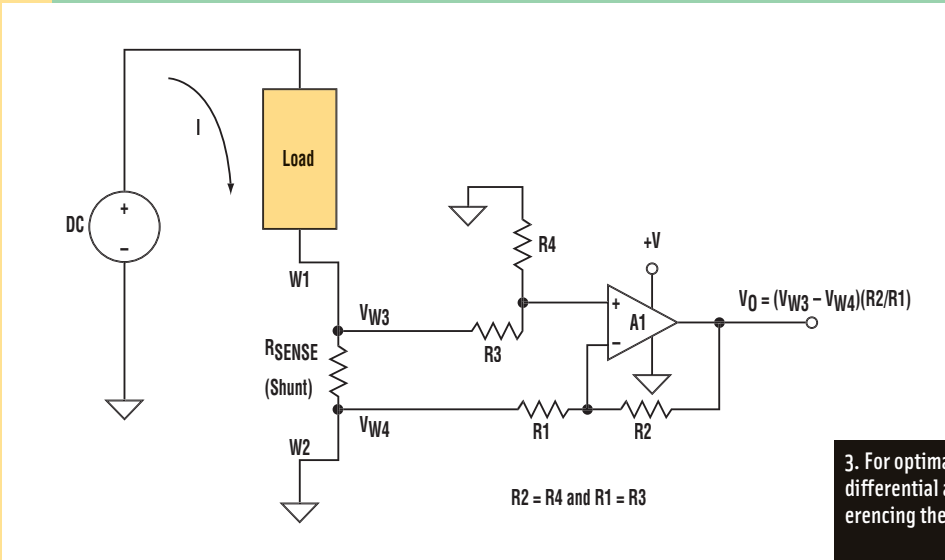

3. For optimal measurement accuracy, a differential amplifier avoids ground-referencing the current-sense voltage.

Low-Side and High-Side Sensing

Placing the sense resistor between the load and ground is called **low-side sensing**.

Low-side sensing is acceptable when the input voltages are positive and close to ground. However, problems arise when op amps are used and those conditions are not met. Low-side current measurements can cause a problem for op amps by exceeding the negative common-mode voltage limit of the op amp.

Due to the way they are designed, op amps only work correctly when the input common-mode voltage is within a certain range between the positive and negative power-supply voltages. A rail-to-rail-input op amp that operates from a single 5-V supply might have a datasheet common-mode input voltage spec of 0 to +5 V.

As an example of a low-side measurement that would create common-mode problems, consider the distributed-load system in Figure 4. A control unit (dashed line) uses MOSFETs to control power to two loads. Parasitic resistances, R_{P1} and R_{P2} , between the power source, the loads, and the control unit represent the sum of ground wiring resistance and connector resistance. In a real circuit, they can easily have values of several tenths of an ohm. For this example, assume R_{P1} and R_{P2} are 0.2 Ω . Differential amplifiers 1 and 2 are just like the differential amplifiers in Figure 3.

As in Figure 1, the current in each load is 10 A, and the shunt resistors (R_{S1} and R_{S2}) are 0.025 Ω . The control unit's current is 1 A. When load two is on, the voltage at point V_{G2} is two volts more positive than point V_{G1} ($0.2 \Omega \times 10 \text{ A} = 2 \text{ V}$), and V_{G3} is 0.2 volts more positive than V_{G2} . As a result, the inputs to differential amplifier 1 are -2.2 V relative to the common connection at the control unit. This is greater than the

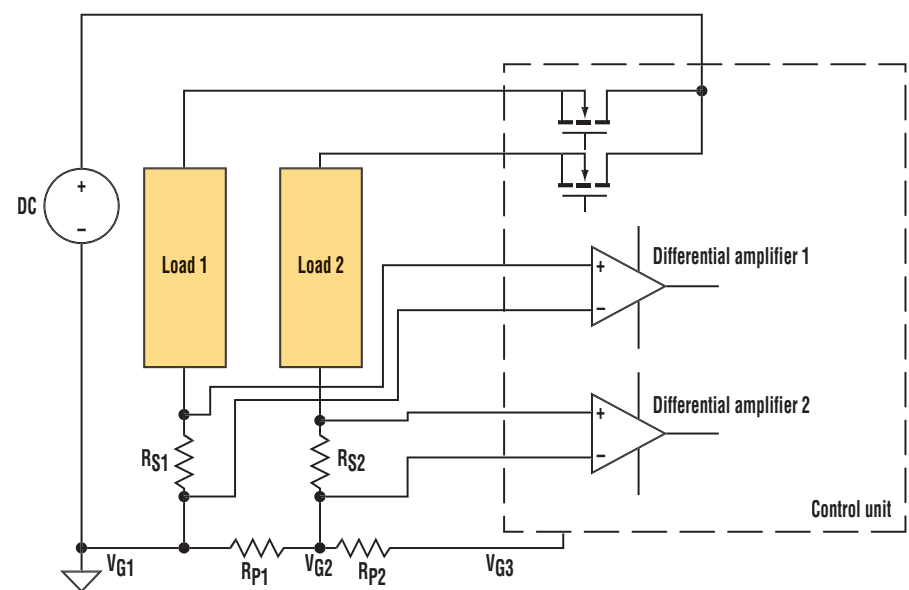

4. Locating the sense resistor between the load and the circuit's common node, a practice called low-side sensing can introduce measurement inaccuracies when parasitic resistances between the sense resistor and the common node are significant.

negative common-mode voltage limit of most amplifiers. Unless the amplifier being used for the differential amp is designed

for negative common-mode voltages, it will not operate correctly in this circuit. (Another disadvantage of low-side sensing in this case is that wiring is required between the shunt resistors and the inputs of the differential amps.)

High-side current sensing solves all of these current-measurement problems (Fig. 5). The shunt resistors are on the supply side of the power source instead of the common side. This arrangement permits the shunt resistors to be mounted in the control unit with the differential amplifiers and MOSFET switches. The wiring from the control module also is simplified.

In this case, the differential amplifiers have to be able to handle an input common-mode voltage equal to the voltage supplied by the power source. One

way to handle this is to operate the differential amplifier from the power source and use an amplifier that has an input common-mode voltage specification that includes the positive supply. Another way is to use an amplifier that is designed for high input common-mode voltages. These have the advantage of operating from the same supply voltage as the other control circuits when the inputs are connected to the higher positive voltage.

In general, measuring current flow in electrical circuits requires amplifiers with input common-mode voltage specifications that extend beyond the positive and negative supply voltages of the amplifier while maintaining low input offset voltage and gain accuracy.

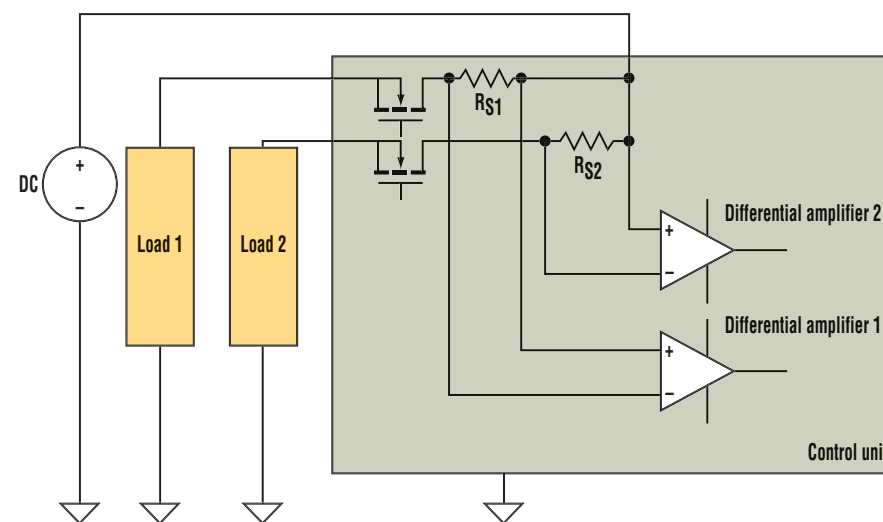

5. High-side sensing eliminates the disadvantages of low-side sensing, but it requires differential amplifiers with inputs that can accommodate the supply voltage within their common-mode input range.