

# Evaluation Board Instruction Manual

**ADC1175: 8-Bit, 20MSPS, 60mW Analog-to-Digital Converter**

**the**

**ADC1175-50: 8-Bit, 50MSPS, 150mW Analog-to-Digital Converter**

**and the**

**ADC1173: 8-Bit, 15MSPS, 33mW Analog-to-Digital Converter**

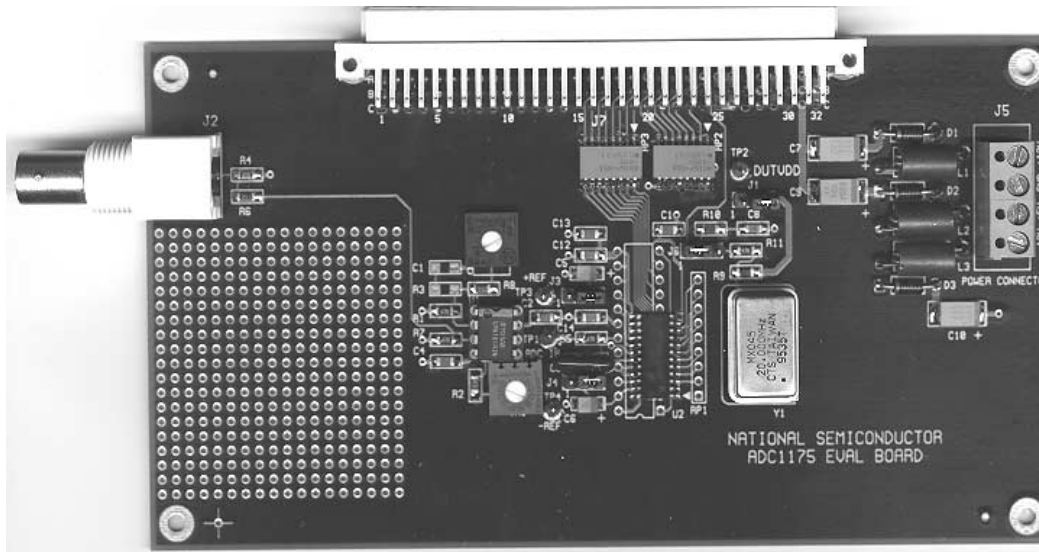

Table of Contents

1.0 Introduction .....4

2.0 Board Assembly.....4

3.0 Quick Start .....4

4.0 Functional Description .....5

    4.1 Input (signal conditioning) circuitry.....5

    4.2 ADC reference circuitry.....5

    4.3 Board Outputs.....5

    4.4 Power requirements.....5

5.0 Installing the ADC1175 Evaluation Board.....5

6.0 Evaluation Board Specifications .....5

7.0 Hardware Schematic.....6

8.0 Evaluation Board Bill of Materials .....7

APPENDIX.....8

    A1.0 Operating in the Computer (Automatic) Mode.....8

    A2.0 The Digital Interface Board and WaveVision Software .....8

    A3.0 Exploring the Video Waveform.....8

        A3.1 Basic Waveform .....8

            A3.1.1 Estimating Differential Gain .....8

            A3.1.2 Looking at Frequency Response .....9

            A3.1.3 Low Frequency Triangle Wave Input .....9

                A3.1.3.1 Monotonicity and Uncertainty .....9

                A3.1.3.2 Rising / Falling Symmetry.....9

        A3.2 The FFT Plot.....10

            A3.2.1 Dynamic Performance Estimates .....10

            A3.2.2 Bandwidth Estimation .....10

    A4.0 Saving and Retrieving Files.....10

        A4.1 Binary Files .....10

        A4.2 ASCII Files.....10

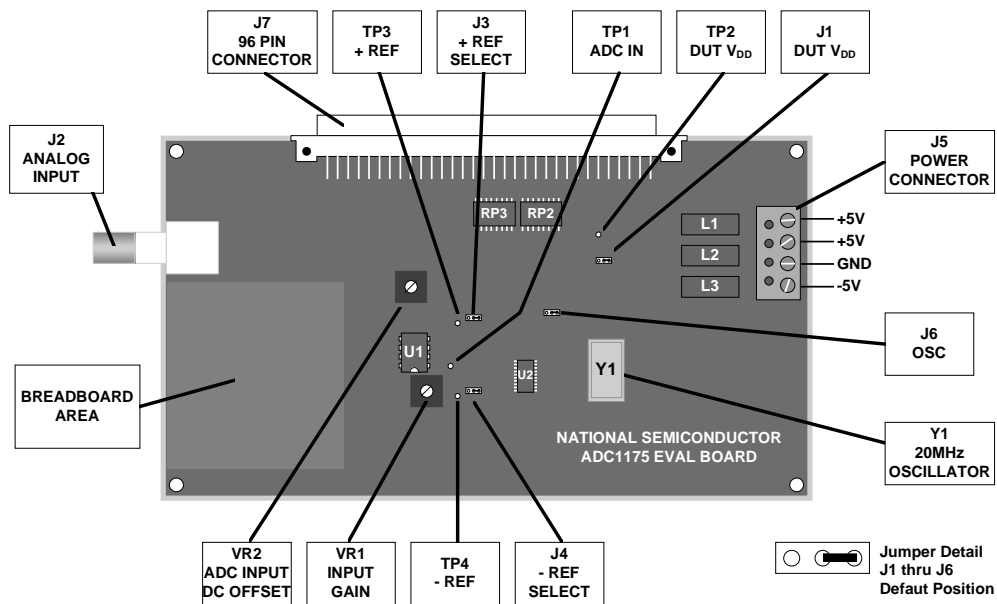

a. ADC1173/ADC1175/ADC1175-50 Eval Board Packaged in TSSOP

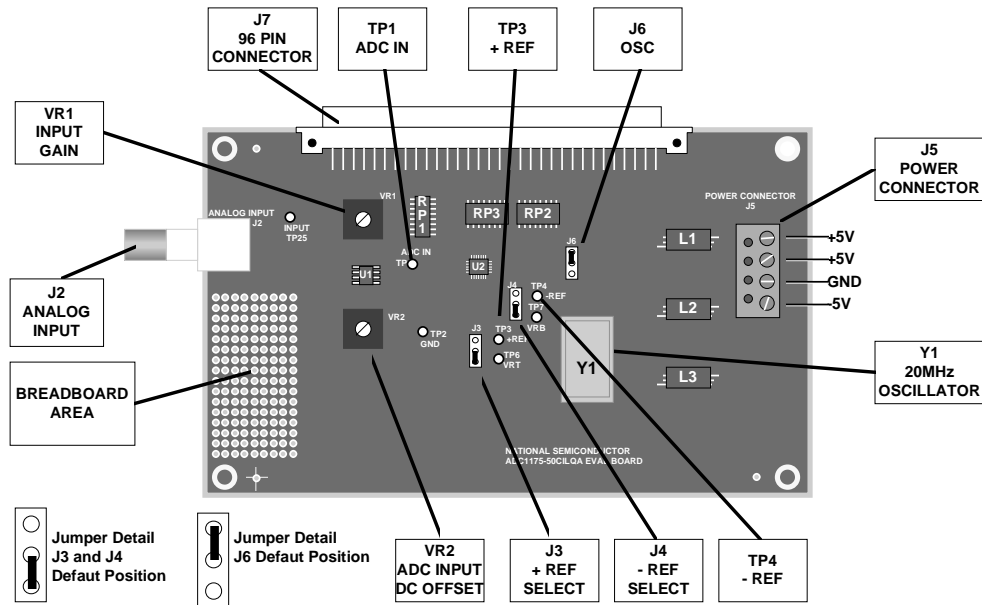

b. ADC1175-50 Eval Board Packaged in LLP

Figure 1. Indicators and Adjustments Locations. Jumpers are shown in default positions

## 1.0 Introduction

The ADC1175EVAL and the ADC1175-50EVALP Evaluation Boards (consisting of the Evaluation Board and this manual) is designed to ease evaluation and design-in of National Semiconductor's ADC1175 20 MSPS, ADC1175-50 50MSPS (in either TSSOP or LLP) and ADC1173 15MSPS Analog-to-Digital Converters. When the ADC1175 is mentioned in this manual, the ADC1175-50 and ADC1173 are also included. The input circuitry for ADC1175-50 board is slightly different from the ADC1175 and ADC1173 and the ADC1175-50 in LLP input circuit is different from the others. See board schematic, Figure 2.

The evaluation board can be used in either of two modes. The first mode is the Manual or Stand Alone mode where the board can be used with suitable test equipment to evaluate the ADC1175's performance.

The second mode is the Computer or Automatic mode. In this mode, evaluation is simplified by connecting the board to the WaveVision Digital Interface Board (order number WAVEVISION BRD), which is connected to a personal computer through a serial communication port, and using National Semiconductor's WaveVision software, which operates under Microsoft Windows 3.1 or later, but NOT Windows NT.

The signal at BNC connector J2 (the Analog Input to the board) is digitized and is available at 96-pin DIN connector J7.

Provision is made for adjustment of gain and offset voltage.

## 2.0 Board Assembly

The ADC1175 Evaluation Board can come as a bare board with a surface mounted ADC1175 or can be purchased fully assembled. Refer to Figure 1 for the location of major components, to Bill of Materials (Section 8.0) for component description and part types and to Figure 2 for the Evaluation Board schematic.

While the oscillator may be soldered to the board, using a socket will allow you to change frequencies and to remove this oscillator when using the board with the Digital Interface Board.

The breadboard area is useful for building customized circuitry. For best performance, keep circuitry neat and arrange components to provide short, direct connections.

## 3.0 Quick Start

Once the board is assembled, the following will allow you to get the board up and running quickly. The digitized signal is available at pins B16 through B19 and C16 through C19 of J7. See the Evaluation Board schematic in Figure 2 for details.

1. Be sure that all jumpers are in their default positions, as shown in Figure 1. If the ADC1173 is being used, set the jumper on J1 so that pins 1 and 2 are connected together and supply a source of 3V to TP2.
2. Be sure there is a crystal in its socket:  
15MHz for the ADC1173  
20MHz for the ADC1175  
50MHz for the ADC1175-50.
3. Connect  $\pm 5V$  and +5V to Power Connector J7.

4. Connect a 1 to 5MHz signal of  $1V_{p-p}$  amplitude from a 75-Ohm source to Analog Input BNC J2.
5. Adjust VR1, Input Gain, and VR2, ADC Input DC Offset, as needed to ensure that the signal at TP1 remains within the limits of the top and bottom reference voltages at TP3 and TP4, respectively.

## 4.0 Functional Description

Figure 2 shows the schematic of the ADC1175 evaluation board. U2 is the device under test. This board supports the ADC1175, ADC1175-50, ADC1173 and ADCs with similar pin connections.

### 4.1 Input (signal conditioning) circuitry.

The input signal to be digitized should be applied to BNC connector J2. This 75 Ohm input is intended to accept any signal input, including composite video, with amplitudes from 1V to 2V peak-to-peak.

The input circuit using U1 (an LM6181 or CLC409) provides a gain of approximately +1 to +2.5, adjustable with VR1. An adjustable offset of  $\pm 300mV$  is controlled by VR2. This can be used to ensure that the signal remains between the top and bottom reference voltages of the ADC1175.

### 4.2 ADC reference circuitry.

The ADC1175 being tested can use the self bias reference included on the IC, or the reference pins of the ADC1175 can be driven with external reference voltages applied to TP3 (+REF) and TP4 (-REF).

You can use the ADC1175's self-bias reference connection by shorting pins 2 and 3 of J3 and of J4. With a +5V supply for the ADC1175, this fixes the top reference voltage at about 2.6V and the bottom reference voltage at about 0.6V. Since the ADC1173 is a 3 Volt device the top reference voltage at about 1.56V and the bottom reference voltage at about 0.36V.

If you short pins 1 and 2 of J3 and of J4, the top and bottom reference pins of the ADC1175 are connected to TP3 and TP4, respectively. External reference voltage sources should then be applied to these test points. The top reference voltage at TP3 should be a minimum of 1V but not below the voltage at TP4 or above the ADC1175 supply voltage, while the lower reference voltage applied to TP4 should be as low as 0V and should never exceed the top reference voltage.

If the difference between the top and bottom reference voltages is small, or if the input signal does not use all or nearly all of the ADC1175 input dynamic range, you could see a degradation of SNR because the size of the LSB becomes small enough to be lost in the system noise. We recommend operating the ADC1175 with a difference of 2V to 2.8V between the top and bottom reference, and driving the ADC1175 analog input such that the peak-to-peak signal at TP1 is about 5mV less than the difference between the voltages at TP3 and TP4.

### 4.3 Board Outputs.

The digital data from the ADC1175 output, as well as a clock signal for this data, is available at the 96 pin DIN Connector J7 (See Figure 2). Pull-up resistors are used at the ADC1175 outputs to ensure adequate drive. Series resistors (RP3) are used to isolate the ADC1175 from any circuits or instruments that it drives.

#### 4.4 Power requirements.

Power to this board is supplied through power connector J7 at the right side of the board. Voltage and current requirements are:

- +5V at 50mA (1.0A with Digital Interface Board)
- +5V at 20mA
- -5V at 20 mA.

The  $\pm 5$ Volt supplies use series diodes to protect the board from accidental polarity reversal, so the board sees voltages of about 600mV below those presented at J7. The 5V supply is protected with a shunt diode. For the ADC1175-50 board, all supplies are protected with shunt diodes.

Power for the ADC1175 can come from the 5V applied to Power Input Connector J7, or from an external 3V to 5V supply applied to TP2. Selection of the ADC1175 supply source is with Jumper J1. See Figure 1. The ADC1175-50LLP board has an adjustable 3 Volt supply source.

#### 5.0 Installing the ADC1175 Evaluation Board

The evaluation board requires power supplies as described in paragraph 4.4. No input signals for evaluation are generated on the board. An appropriate signal generator (such as the HP3325B, HP8662A or the Tektronix TSG130A) with 75-Ohm source impedance should be connected to the Analog Input BNC, J2.

**NOTE:** The board comes with a surface mounted ADC1175. If you remove this device and install a DIP in the holes provided (for the non-LLP board), note that the ADC1175 is rotated 180 degrees from what might be considered the normal orientation.

If this board is used in conjunction with the Digital Interface Board and WaveVision software, a cable with a DB-9 connector should be connected between the Digital Interface Board and the host computer. See the Digital Interface Board manual for details.

#### 6.0 Evaluation Board Specifications

Board Size:	3.5" x 6.3" (8.9 x 16 cm)
Power Requirements:	+5V @ 50 mA *
	+5V @ 75 mA
	-5V @ 100 mA
Clock Frequency Range:	1 MHz to 20 MHz
Analog Input	
Nominal Voltage:	1V <sub>P-P</sub>
Impedance:	75 Ohms
Normal board Input Range:	0.5V to 1.0V

\* +5V supply must supply 1.0 Amps when this demo board is used with the Digital Interface board.

# 7.0 Hardware Schematic

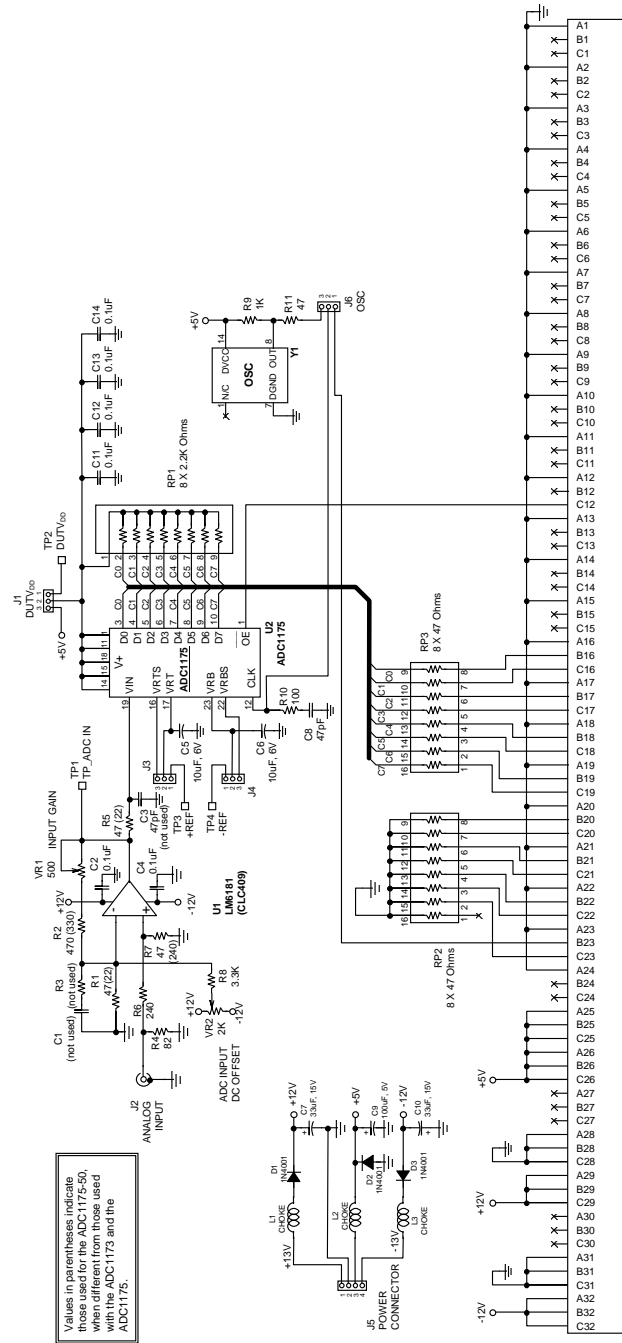

Figure 2a. Eval Board Schematic for TSSOP

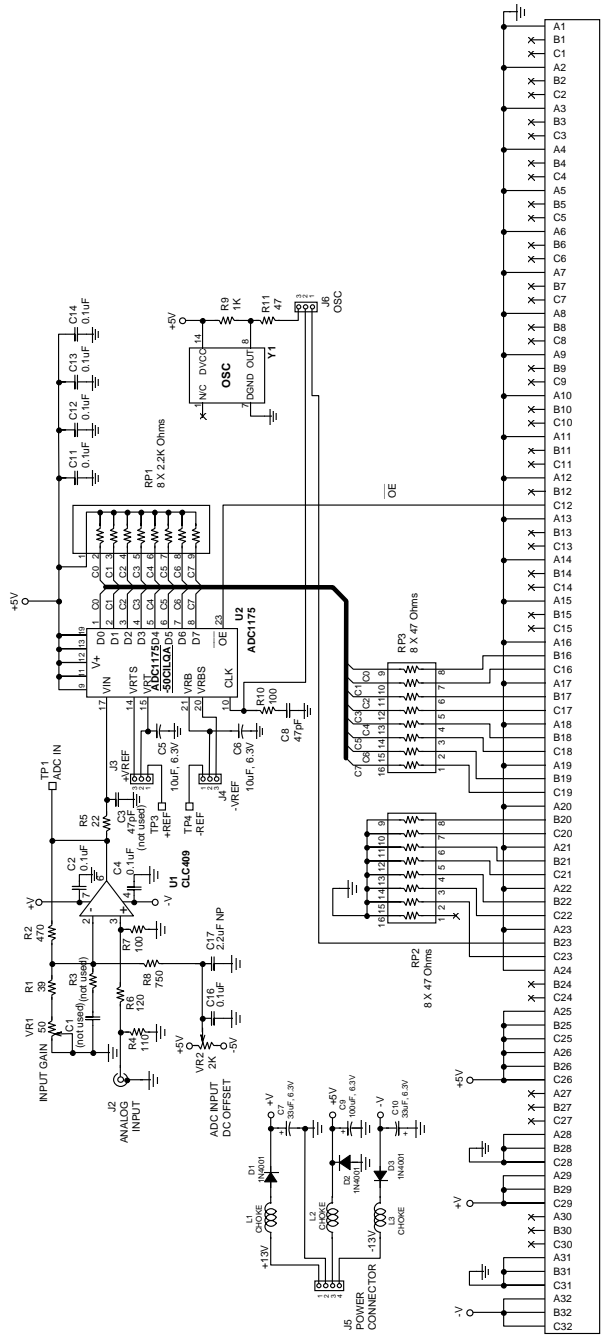

Figure 2b. Eval Board Schematic for LLC

J7 96 PIN FEMALE EURO DIN CONNECTOR

## 8.0 Evaluation Board Bill of Materials

C1, C3	not used	--
C8	47pF	Type 0805
C2, C4, C11, C12, C13, C14	0.1uF	Type 0805
C5, C6	10uF, 6.3V	Type 3216 [A size]
C7, C10	33uF, 6.3V	Type 7343 [D size]
C9	100uF, 6.3V	Type 7343 [D size]
D1, D2, D3	1N4001	Various
J1	not used	--
J3, J4, J6	3-PIN Post Header	DigiKey # A19351-ND
J2	BNC	DigiKey # ARF1177-ND
J5	2-Post Terminal Block [2 needed]	DigiKey # ED1605-ND
J7	96 Pin Female DIN Connector	DigiKey # H7096-ND
L1, L2, L3	Choke	DigiKey # M2304-ND
R1	22 $\Omega$ (ADC1175-50 TSSOP), 39 $\Omega$ (LLP), 47 $\Omega$ (others)	Type 0805
R3	not used	--
R5	22 $\Omega$ (ADC1175-50), 47 $\Omega$ (others),	Type 0805
R7	240 $\Omega$ (ADC1175-50T SSOP), 100 $\Omega$ (LLP), 47 $\Omega$ (others)	Type 0805
R10	100 $\Omega$	Type 0805
R11	47 $\Omega$	Type 0805
R2	330 $\Omega$ (ADC1175-50T SSOP), 240 $\Omega$ (LLP), 470 $\Omega$ (others)	Type 0805
R4	110 $\Omega$ (ADC1175-50T SSOP), 82 $\Omega$ (others)	Type 0805
R6	120 $\Omega$ (ADC1175-50T SSOP), 240 $\Omega$ (others)	Type 0805
R8	750 $\Omega$ (ADC1175-50T SSOP), 3.3k $\Omega$ (others)	Type 0805
R9	1k $\Omega$	Type 0805
RP1, RP2, RP3	8 X 2.2k $\Omega$	DigiKey # 4310R-1-222-ND
TP1, TP2, TP3, TP4	Breakable Header	DigiKey # S1012-36-ND
--	Shorting Jumper [4 needed]	DigiKey # S96001-ND
U1	LM6181IN (CLC409AJP)	National
U2	ADC1175CIMJ	National
VR1	50 $\Omega$ (ADC1175-50 TSSOP), 500 $\Omega$ (others) [Gain Adjust]	DigiKey # 3386F-500-ND
VR2	2k $\Omega$ [Offset Adjust]	DigiKey # 3386F-202-ND
Y1	50MHz Oscillator	DigiKey # CTX-216-ND
Socket	for Y1	DigiKey # A462-ND

## APPENDIX

### WaveVision and Computer Mode Operation with the Digital Interface Board

#### A1.0 Operating in the Computer (Automatic) Mode

When using the ADC1175 evaluation board with the Digital Interface Board for Computer mode operation, you should short pins 1 and 2 of Jumper J6 on the ADC1175 evaluation board. This connects the clock oscillator from the Digital Interface Board to the ADC1175's clock input pin. It is also a good idea to remove the crystal from the ADC1175 eval board for Computer mode operation to prevent noise problems.

Follow these steps to operate the board in the Computer mode. Refer to Figure 1.

1. Set up the Digital Interface Board per the instructions in the Digital Interface Board manual.
2. Adjust VR1 and VR2 for gain and offset, as desired. Note that SNR performance may not be as good with this circuit as with a low impedance driver for the reference voltages. See the ADC1175 data sheet for better circuits.
3. Use WaveVision to set up the board (See the Digital Interface Board Manual). Remember that the clock frequency on the board is set by Program Switch of the Digital Interface Board. See the Digital Interface Board manual for more information.
4. Select the desired number of samples to acquire (ALT, P, B or CTRL-P. See the Digital Interface Board manual).
5. Once data transfer is complete, portions of the waveform may be selected for viewing by clicking the mouse pointer at one corner of the area to be viewed and dragging to the opposite corner. Restore the full display by right clicking over the display.

If desired, an FFT may be performed on the captured data (ALT, P, F or CTRL-F or click on FFT icon. See Appendix of the Digital Interface Board manual).

#### A2.0 The Digital Interface Board and WaveVision Software

To fully evaluate the ADC1175 with minimal external equipment, you need the WaveVision Evaluation Kit (order number WAVEVISION BRD, WAVEVSN BRD 2.0 or WAVEVSH BRD 3.0). This kit consists of a Digital Interface Board that connects the ADC1175 Evaluation board through the 96-pin DIN connector, a serial cable for connecting the Digital Board to a computer and a 3.5" program diskette with all the software needed to control the combined Digital Interface Board and ADC1175 Evaluation board.

#### A3.0 Exploring the Video Waveform

WaveVision software and the ADC1175 Evaluation Board add a new tool to the video designer's toolbox. The evaluation board, together with the Digital Interface Board, can be used to capture a video signal. The captured data can then be displayed and performance parameters can be measured.

See the Appendix of the Digital Interface Board manual for WaveVision screen drawings that show software operation.

##### A3.1 Basic Waveform

After the ADC1175 Evaluation Board has uploaded a captured waveform to the PC, WaveVision displays this waveform on the computer monitor. The WaveVision software can be used to evaluate the ADC1175's performance.

##### A3.1.1 Estimating Differential Gain

To estimate differential gain of the circuit, capture a modulated video ramp and measure the peak-to-peak amplitude of the subcarrier (3.58 MHz for NTSC, 4.43 MHz for PAL) at the white (highest) level and at the black (lowest) level. The percentage difference between these two levels is an estimate of differential gain.

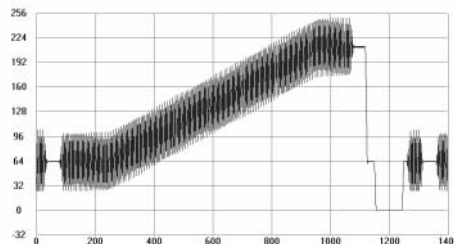

Figure 5. Modulated ramp of a video signal. The chroma level near black, subtracted from the chroma level near white will give an estimate of overall differential gain of the circuit.

Figures 6 and 7 show enlargements of the black level and the white level, respectively, of the signal in Figure 5.

Another method of estimating differential gain (without a modulated video ramp), is to capture a pure, stable continuous wave at two different d.c. levels. The peak-to-peak amplitude of the sine wave should be about 25% of the input full scale swing, or about  $500\text{mV}_{\text{p-p}}$  with a 2V reference span.

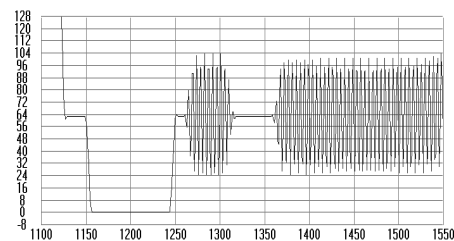

Figure 6. Enlargement of the black level area of the modulated ramp of Figure 5 showing the digital values of the chroma information.

First, capture the waveform with the offset adjust potentiometer, VR2, set to give an average code of about 64 at the ADC output. This would correspond to a DC potential of about 1.1V at the ADC input (TP1) with a nominal 2.6V and 0.6V at the top and bottom reference inputs, respectively. Measure the peak-to-peak level of this signal on the screen.

Then capture another waveform with the offset adjust potentiometer, VR2, set to give an average code of about 192 at the ADC output. This would correspond to an input DC potential of about 2.1V at the ADC input (TP1, Figure 1 and Figure 2). Measure the peak-to-peak level of this signal. You might want to open a new window for this second waveform capture, so that both levels may be displayed at once.

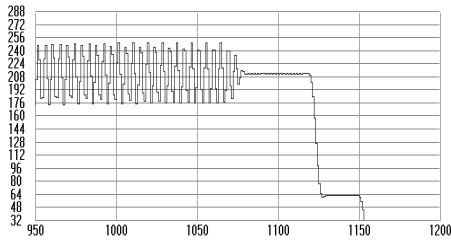

Figure 7. Enlargement of the white level area of the modulated ramp to be compared with the black level. The percentage difference between the two chroma levels is differential gain.

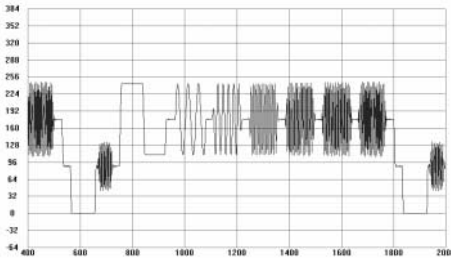

Figure 8. This multiburst signal shows the gain flatness of the overall circuit. Notice that all frequencies have about equal amplitude.

The estimated differential gain is the percentage difference in the peak-to-peak readings of these two signals.

### A3.1.2 Looking at Frequency Response

A video multiburst signal can be used to evaluate system frequency response. This approach will show the overall system response, including any input signal conditioning.

A multiburst signal has bursts of fixed frequencies, one after the other, that usually start at 0.5 MHz and increase to 4.5 MHz or 5.5 MHz, depending upon the video standard.

Figure 8 shows a captured PAL multiburst signal. Note the flat response, with all frequency components at the same amplitude.

The individual preset frequencies of the multiburst signal can be determined by performing an FFT on the data, (Figure 9). The individual frequencies are, in this case, 0.5, 1, 2, 4, 4.75 and 5.75 MHz. The dynamic data to the right of the spectrum plot is useless for such data.

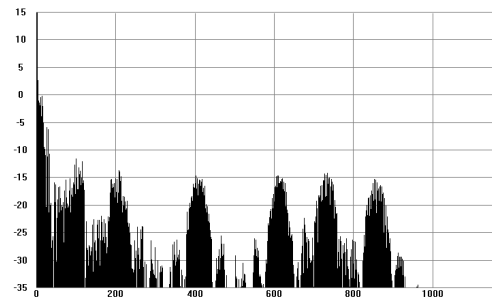

Figure 9. This FFT of the multiburst signal shows frequency on the horizontal axis, allowing a measurement of the bandwidth required for the burst of each frequency. This spectrum of the whole video signal indicates the bandwidth required to pass this signal without distortion.

### A3.1.3 Low Frequency Triangle Wave Input

A low frequency (about 15KHz) triangle wave will provide general information on ADC performance.

#### A3.1.3.1 Monotonicity and Uncertainty

When a voltage ramp is digitized, the code sequence shows increasing codes up to the peak level, or decreasing codes to the minimum level, depending upon whether the slope of the ramp. A waveform with always increasing or decreasing codes is said to be monotonic, as in Figure 10a.

A converter that has one or more instances of codes consistently going in the wrong direction is said to be non-monotonic. See Figure 10b.

When digitizing signals with rise and fall times slow enough to result in more than one conversion result of the same code in sequence, it is normal to have some code uncertainty when the input is at a code transition point. See Figure 11.

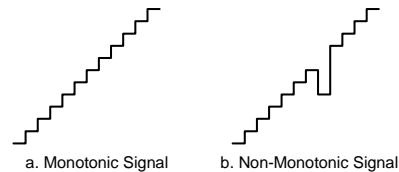

Figure 10. Monotonicity means codes are continually increasing or decreasing.

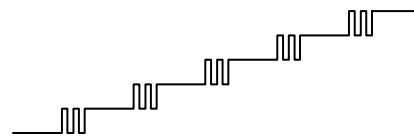

Figure 11. Code uncertainty when the ADC input voltage is near a code transition point.

#### A3.1.3.2 Rising / Falling Symmetry

The ideal A/D converter will give the same code when digitizing a given input voltage whether that voltage is approached from a lower voltage or from a higher voltage. If a

*symmetrical* triangle wave is presented to the ADC, the falling side of the reconstructed waveform should be a mirror image of the rising side at the input and at the output. In practice, however, this may not be the case. Looking at the WaveVision data display of a digitized triangle wave will show how symmetrical the two slopes are with respect to each other. Choose your generator with care as *many triangle wave signal generators have non-symmetrical slopes*.

### A3.2 The FFT Plot

At the right side of the FFT plot are dynamic performance estimates of SINAD, SNR, THD and SFDR (Spurious-Free Dynamic Range). These readings are meaningful only for a sine wave input to the ADC and are accurate only to the extent that the input waveform is stable and contains a single frequency.

Harmonics and other interfering signals at the input can be attenuated by inserting an appropriate filter at the Analog Input. The elliptic filters of Figures 12 and 13 are examples of suitable filters for input frequencies of 1MHz to 5MHz and for 5MHz to 10MHz, respectively. These filters can filter a square wave, reducing 3rd and higher harmonics to negligible levels.

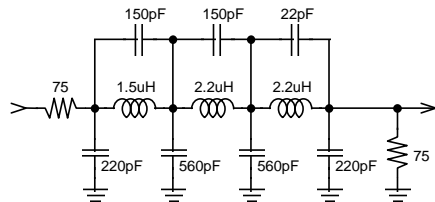

Figure 12. This 4MHz cutoff elliptic filter can be used for input frequencies of 1MHz to 4MHz. It should be driven by a generator of 75 Ohms source impedance and terminated with 75 Ohms. This termination is provided by the ADC1175 evaluation board. The input resistor shown here is normally the generator output impedance.

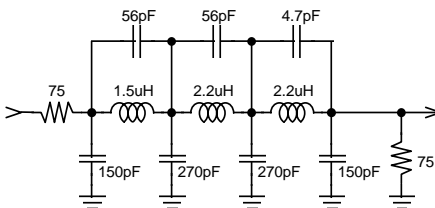

Figure 13. This elliptic filter has a cutoff frequency of about 11MHz and is suitable for input frequencies of 5MHz to 10MHz. Other comments relating to Figure 12 apply here.

The FFT plot, however, can provide other information from captured signals other than single frequency sinusoids. One example is shown in Figure 9.

#### A3.2.1 Dynamic Performance Estimates

The dynamic performance as indicated by SINAD, SNR, THD and SFDR are estimates rather than hard and fast figures because their accuracy depends upon how much of the ADC1175's dynamic input range is used, and how many samples are taken.

For example, if the input is reduced below a full scale swing such that the maximum and minimum codes obtained at the output are 235 and 20, rather than the full scale values of 255 and 0, only about 84% of the code range is used. The result is an apparent degradation of SNR. On the other hand, if the input exceeds the input dynamic range such that the top and bottom of the input signal is clipped at the ADC1175's output, THD, SFDR and SINAD will be degraded.

Furthermore, apparent performance may be limited by the purity of the input signal used.

#### A3.2.2 Bandwidth Estimation

If a constant amplitude frequency sweep is applied at the Analog Input (J2) and the signal at the ADC input is digitized and displayed, the data display will show any frequency dependent amplitude variation.

### A4.0 Saving and Retrieving Files

WaveVision allows you to save data in two formats. One is a binary file, the other is an ASCII file. See the Digital Interface Board manual.

#### A4.1 Binary Files

To save a binary file for use later by WaveVision, you can either click on the save icon, enter ALT, F, S or enter CTRL-S. You will be prompted for a file name the first time you save a given set of data. The binary file created contains information as to program settings as well as the raw data.

To retrieve a binary file in WaveVision, you may click on the Open File icon, enter ALT, F, O or enter CTRL-O. You will be prompted for the name of the file you wish to retrieve.

#### A4.2 ASCII Files

To export an ASCII file for use later by another program, such as Excel, you must enter ALT, F, D. You will be prompted for a file name.

The ASCII file will contain only raw data with one data point per line.

To import an ASCII file, whether created with WaveVision or with any other program or utility, enter ALT, F, I. You will be prompted for the name of the file you wish to retrieve. Remember that imported files must have one data point per line and should have a binary weighted number of samples.

The ADC1175 Evaluation Board is intended for product evaluation purposes only and is not intended for resale to end consumers, is not authorized for such use and is not designed for compliance with European EMC Directive 89/336/EEC.

WaveVision is a trademark of National Semiconductor Corporation. National does not assume any responsibility for use of any circuitry or software supplied or described. No circuit patent licenses are implied.

#### LIFE SUPPORT POLICY

NATIONAL'S PRODUCTS ARE NOT AUTHORIZED FOR USE AS CRITICAL COMPONENTS IN LIFE SUPPORT DEVICES OR SYSTEMS WITHOUT THE EXPRESS WRITTEN APPROVAL OF THE PRESIDENT OF NATIONAL SEMICONDUCTOR CORPORATION. As used herein:

1. Life support devices or systems are devices or systems which, (a) are intended for surgical implant into the body, or (b) support or sustain life, and whose failure to perform, when properly used in accordance with instructions for use provided in the labeling, can be reasonably expected to result in a significant injury to the user.
2. A critical component is any component in a life support device or system whose failure to perform can be reasonably expected to cause the failure of the life support device or system, or to affect its safety or effectiveness.



---

**National Semiconductor Corporation**  
Americas  
Tel: 1-800-272-9959  
Fax: 1-800-737-7018  
Email: support@nsc.com

**National Semiconductor Europe**  
Fax: +49 (0) 1 80-530 85 86  
Email: europe.support@nsc.com  
Deutsch Tel: +49 (0) 1 80-530 85 85  
English Tel: +49 (0) 1 80 532 78 32

**National Semiconductor Asia Pacific Customer Response Group**  
Tel: 65-2544466  
Fax: 65-2504466  
Email: sea.support@nsc.com

**National Semiconductor Japan Ltd.**  
Tel: 81-3-5639-7560  
Fax: 81-3-5639-7507

---

[www.national.com](http://www.national.com)

National does not assume any responsibility for any circuitry described, no circuit patent licenses are implied and National reserves the right at any time without notice to change said circuitry and specifications.