

# Application Brief

## Thermal Performance of National's LLP Package, Highlighting the LM2750 Regulated Voltage Converter

Application Brief 111

Brian J. Conner

National's Leadless Leadframe Package (LLP) provides excellent power dissipation capability in a very small package footprint. The LLP is a chip scale package that requires minimum PCB footprint area. Unlike conventional leaded plastic packages, the LLP contains pads on the bottom of the package for PCB mounting, as shown in *Figure 1*. One obvious benefit of the self-contained pads is that, by not extending beyond the edges of the plastic, PCB area is not wasted to accommodate connectivity. Another key benefit of LLP is achieved with the exposed die attach pad (DAP), the large pad in the center of the package (see *Figure 1*). This pad acts as an "embedded heat-sink", efficiently dissipating heat away from the part through the PCB. The terrific thermal dissipation that this special pad provides allows high-power parts packaged in the LLP to operate without overheating, even at elevated ambient temperatures.

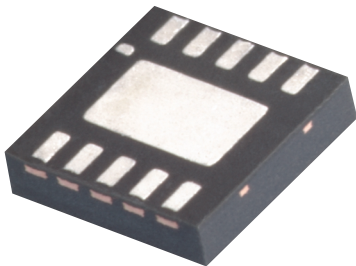

*Figure 1: Leadless Leadframe Package (LLP) – Bottom View  
Shown - 10-lead dual-inline LLP (3.0 mm x 3.0 mm x 0.8 mm)*

### LLP vs. SOT-23

The power dissipation benefits of the LLP are readily apparent when this package is compared to a very popular industry workhorse: the SOT-23. Evaluating the 10-lead LLP side-by-side with the 6-lead SOT-23 gives the following:

- Both the LLP-10 and the SOT23-6 occupy a 3 mm x 3 mm footprint
- LLP-10 has a smaller profile: 0.8 mm height vs. the 1.1 mm height of the SOT23-6
- The junction-to-ambient thermal resistance ( $\theta_{JA}$ ) of the LLP-10 is 54°C/W. The  $\theta_{JA}$  of the SOT23-6 is 218°C/W. ( $\theta_{JA}$  measured according to the JEDEC standard)\*

Without occupying any extra board area, and with a lower profile, the LLP-10 is over 4 times more efficient at dissipating heat away from the silicon than the SOT23-6. This tremendous advantage allows parts in the LLP to consume much more power without overheating than similar parts packaged in the SOT-23 (or other similar low power packages).

### LM2750 in the LLP-10

A National part that benefits greatly from the thermal dissipation properties of the LLP is the LM2750. The LM2750 is a power supply integrated circuit that provides a regulated 5.0V output from an input voltage in the range of 2.9V to 5.6V. The part is capable of supplying up to 120 mA of output current.

For power dissipation purposes, the architecture of the LM2750 can be modeled as a switched capacitor voltage doubler followed by a linear regulator, as shown in *Figure 2*. The power dissipated in the LM2750 can be approximated by:

$$P_D = P_{IN} - P_{OUT} = V_{IN} \times (2 \times I_{OUT} + I_Q) - V_{OUT} \times I_{OUT}$$

The equation above takes the input current of the LM2750 to be equal to twice the output current, as should be expected with a switched capacitor doubler. The equation also contains an additional supply current factor ( $I_Q$ ). Evaluation of the LM2750 has shown this input current approximation to be very accurate, and  $I_Q$  has been measured to be 5 mA (typ.).

Advertisement

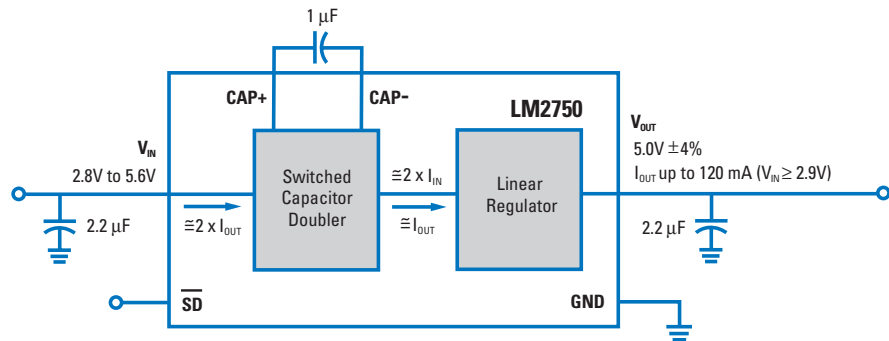

Figure 2: Model of the LM2750 (Simplified model intended for power dissipation calculations only)

If the input voltage is taken to be 5.5V, and the output current is set to 120 mA, the power dissipated in the LM2750 can be calculated:

$$P_D = 5.5V \times (2 \times 120 \text{ mA} + 5 \text{ mA}) - 5.0V \times 120 \text{ mA} = 750 \text{ mW}$$

If a 54°C/W junction-to-ambient thermal resistance is assumed for the LLP, the result is a 40° rise in die temperature within the LM2750. Thus, even under these demanding conditions, the LM2750 can be operated in an ambient temperature of 85°C and the die temperature will not exceed the maximum junction temperature operating rating of 125°C.

If the LM2750 were in a SOT23-6 package, with a  $\theta_{JA}$  of 218°C/W, the junction temperature under identical electrical and environmental conditions would be 250°C! (In actuality, thermal protection circuitry would prevent the die temperature from ever exceeding 150°C). The part could not possibly operate under such extremes, and would have to be derated. With an input voltage of 5.5V and an ambient temperature of 85°C, the maximum output current that the LM2750 could provide if it were in a SOT23-6 package would be only 25 mA, much less than the 120 mA capability of the LLP-packaged LM2750.

## Summary

The LLP package is clearly a superior power package that gives excellent thermal dissipation in a very small size. In this brief, only the LLP-10 has been mentioned. There are several other LLP packages available, with pin counts ranging from 6 to 56. Please refer to [www.national.com](http://www.national.com) for more information on all of National's LLP offerings. A final note regarding thermal performance of the LLP: To achieve maximum performance from the package, the PCB should be designed to aid LLP thermal dissipation. Metal on the PCB helps dissipate heat away from the part. Connecting the DAP to large areas of top-side metal and/or internal power planes (through vias) is not only recommended, it may be required. For more information on issues concerning PCB design related to the LLP, please refer to Application Note AN-1187.

## Additional Information

[power.national.com](http://power.national.com)  
[www.national.com/packaging](http://www.national.com/packaging)  
[www.national.com/pf/LM/LM2750.html](http://www.national.com/pf/LM/LM2750.html)  
[www.national.com/an/AN/AN-1187.pdf](http://www.national.com/an/AN/AN-1187.pdf)

References:  
 App Note 1187 – Leadless Leadframe Package (LLP)

**Visit The National Edge, our online technical journal for an archive of Application Briefs and other interesting information.**  
[edge.national.com](http://edge.national.com)

**National Semiconductor**  
 2900 Semiconductor Dr.  
 PO Box 58090  
 Santa Clara, CA 95052  
 1-800-272-9959

Visit our web site at:  
[www.national.com](http://www.national.com)

For more information,  
 send email to:  
[new.feedback@nsc.com](mailto:new.feedback@nsc.com)

 **National Semiconductor**  
 The Sight & Sound of Information

\* Thermal dissipation figures obtained according to the following JEDEC standards:  
 LLP-JESD51-7; SOT-23-JESD51-3

© National Semiconductor Corporation, 2002. National Semiconductor and  are registered trademarks of National Semiconductor Corporation. All rights reserved.