

Adjustable 3-Terminal Regulator for Low-Cost Battery Charging Systems

With the introduction of the LM317, a 3-terminal adjustable regulator, it becomes relatively easy to design high-performance, low-cost battery charging systems. Even single battery cells can be charged on this new regulator, which is adjustable down to 1.2V. The internal protection circuitry can be used to limit charging current as well as to protect against overloads. The output voltage is easily adjusted so multiple voltage chargers can be made.

The ability to accurately adjust the output voltage of the LM317 makes it especially attractive for constant voltage battery charging applications. Batteries are most quickly charged by "constant-voltage" charging circuits; however, close control of the charging voltage is necessary to prevent overcharging, especially with nickel cadmium cells. The internal protection circuitry of the LM317 is helpful in protecting against accidental overload conditions commonly occurring in charging systems.

Internal Current Limit

The peak charging current or output current is controlled by the internal current limit of the LM317. This current limit will work even if a battery is connected backwards to the output of the charger. Should a fault condition exist for an extended period of time, the thermal limiting circuitry will decrease the output current, protecting the regulator as well as the transformer. A constant voltage charger circuit is shown in *Figure 1*. The output voltage is set with resistors R2 and R3 and given by

$$V_{OUT} = 1.25 \left(1 + \frac{R3}{R2} \right)$$

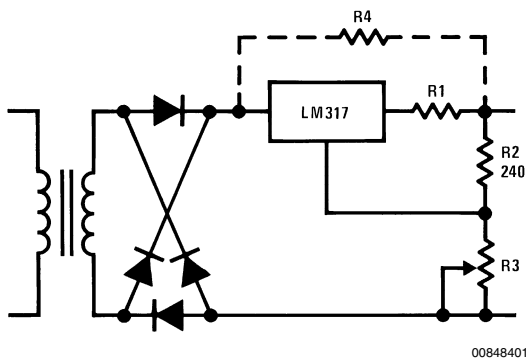

FIGURE 1. Constant Voltage Charging Circuit

Since, in low cost applications, no filter capacitors are used on the output of the rectifier, the battery is only charged on the peaks of the sine wave. This requires the peak output voltage from the transformer to be at least 50% greater than the battery voltage plus 3V. However, little cost premium should result since the average current from the transformer is lower than capacitive input filter circuits. Optional resistors R1 and R2 are used to further control the charging characteristics. Resistor R1 controls the output impedance of the

National Semiconductor
Linear Brief 35
August 1976



charger allowing a "taper-charge" characteristic to be generated. The LM317 can also be used to limit the peak charging current to a partially charged battery at a value other than the regulator current limit. With R1 in the circuit, the output impedance is:

$$Z_{OUT} = R1 \left(1 + \frac{R3}{R2} \right)$$

Including R1 in the feedback loop decreases the value of resistor needed for a particular output impedance reducing cost and power dissipation.

For example, with a 6V gelled electrolyte battery the regulator can be set to give a 6.9V output. Nominally, the battery is discharged to about 5V, making R1 0.4Ω output impedance and limiting the charging current to 0.5A at the start of charging rather than the internal current limit of the regulator. With a fully discharged battery or under short circuit conditions, the peak output current is still 2A for the LM317K with the resistor dissipating 1.6A as opposed to 8W if a 2Ω resistor were used directly in series with the battery.

Resistor R4 can be included to provide a low "topping-up" current for a charged battery.

This regulator configuration provides some other important features to the charger. If input power is removed and a fully charged battery is connected to the charger output, there is no damage. Under these conditions about 5 mA of current will be drawn by divider R2, R3. Since there is no ground connection to the LM317 regulator, very little current flows through the LM317. In this respect, the LM317 differs from other 3-terminal regulators, which can be damaged by applying power to the output terminal with the input open-circuited. If the battery is connected backwards, the LM317 will current limit and thermal limit normally, protecting the charger.

Decreasing Current Limit

Adding a single NPN transistor can be used to decrease the current limit of the charge as shown in *Figure 2*.

Decreasing Current Limit (Continued)

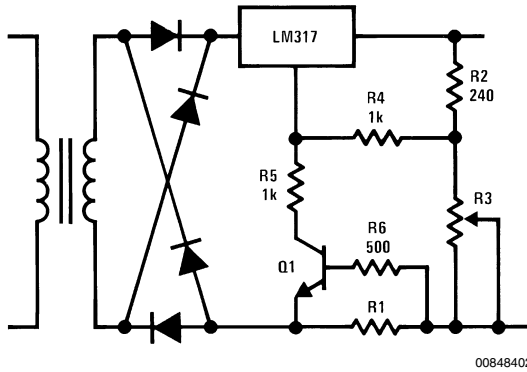

FIGURE 2. Constant Voltage Charger with Peak Current Limiting

Resistor R1 senses the output current and turns on Q1 when I_{OUT} R1 equals about 0.6V. Transistor Q1 pulls the adjustment terminal negatively decreasing the output voltage and controlling the output current. A limitation of this circuit is that it does not work for direct short circuits. The output voltage must be above about 0.6V for the external current limiting to be active. The internal current limit of the LM317, of course, is still operative. This is not usually a problem since batteries charge to above 0.6V very quickly. Resistors R4, R5 and R6 protect the regulator and transistor for both direct short circuits or reverse battery connections.

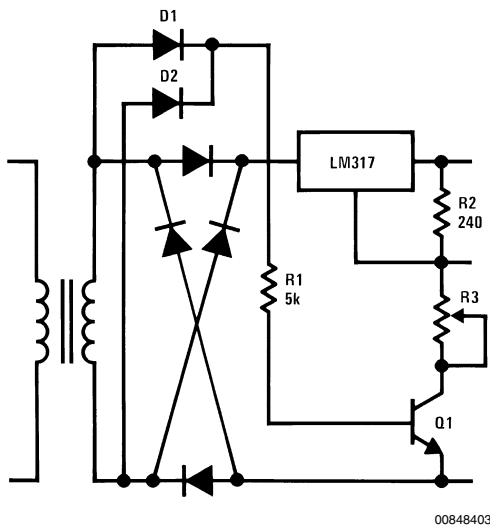

FIGURE 3. Charger with No Battery Loading when Power is "OFF"

As illustrated in *Figure 3*, in float or standby applications, it is desirable to remove all loading from the battery when input power is "OFF." When power is "ON," Q1 is saturated, grounding the voltage setting divider R2, R3 and the circuit works in a similar manner to the charger circuit in *Figure 1*. When power is "OFF," Q1 is open, eliminating any loading on the battery. A separate pair of low current diodes D1, D2 are necessary to bias Q1, rather than the power bridge rectifier. If R1 was tied to the output of the bridge, reverse current flow through the LM317 would keep Q1 "ON" and loading the battery.

A simple constant current charger for any type of battery is shown in *Figure 4*. A resistor R1 between the adjustment terminal and the output of the regulator sets the output current at:

$$I_{OUT} = \frac{1.25}{R1}$$

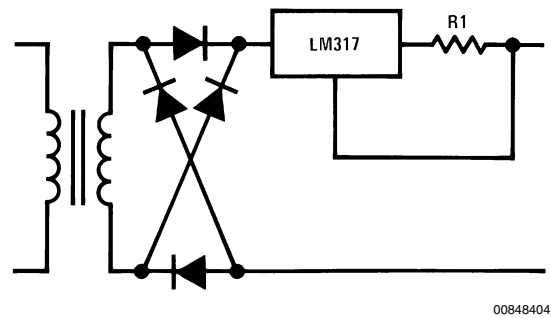

FIGURE 4. Constant Current Charger

Current can be set at anywhere between 10 mA and 1.5A by appropriate resistor choice. Current regulation is very tight at any current level since only 50 μ A flows out of the adjustment terminal. This circuit is also immune to damage from shorts or reverse battery connections. The input voltage for regulation should also be about 1.5 times the battery voltage plus 3V.

Uniquely Suited

The ability to adjust the output of the LM317 3-terminal regulator makes it uniquely suited for battery charging systems. Little has been included about charging specific types of batteries, since the characteristics of the charger should be matched to the battery. These charger circuits, although very simple, perform well. They are easily modified for voltage, current or even temperature coefficient by making the divider string temperature sensitive. More complex chargers can be made since the output of the LM317 is easily controlled by driving the adjustment terminal. Finally, the chargers are inherently protected against overloads and fault conditions.

Notes

LIFE SUPPORT POLICY

NATIONAL'S PRODUCTS ARE NOT AUTHORIZED FOR USE AS CRITICAL COMPONENTS IN LIFE SUPPORT DEVICES OR SYSTEMS WITHOUT THE EXPRESS WRITTEN APPROVAL OF THE PRESIDENT AND GENERAL COUNSEL OF NATIONAL SEMICONDUCTOR CORPORATION. As used herein:

1. Life support devices or systems are devices or systems which, (a) are intended for surgical implant into the body, or (b) support or sustain life, and whose failure to perform when properly used in accordance with instructions for use provided in the labeling, can be reasonably expected to result in a significant injury to the user.
2. A critical component is any component of a life support device or system whose failure to perform can be reasonably expected to cause the failure of the life support device or system, or to affect its safety or effectiveness.



National Semiconductor Corporation
Americas
Email: support@nsc.com

www.national.com

National Semiconductor Europe

Fax: +49 (0) 180-530 85 86
Email: europe.support@nsc.com
Deutsch Tel: +49 (0) 69 9508 6208
English Tel: +44 (0) 870 24 0 2171
Français Tel: +33 (0) 1 41 91 8790

National Semiconductor Asia Pacific Customer Response Group

Tel: 65-2544466
Fax: 65-2504466
Email: ap.support@nsc.com

National Semiconductor Japan Ltd.

Tel: 81-3-5639-7560
Fax: 81-3-5639-7507