

High Stability Regulators

National Semiconductor
Linear Brief 15
January 1971



Monolithic IC's have greatly simplified the design of general purpose power supplies. With an IC regulator and a few external components 0.1% regulation with 1% stability can be obtained. However, if the application requires better performance, it is advisable to use some other design approach.

Precision regulators can be built using an IC op amp as the control amplifier and a discrete zener as a reference, where the performance is determined by the reference. *Figures 1, 2* show schematics of simple positive and negative regulators. They are capable of providing better than 0.01% regulation for worst case changes of line, load and temperature. Typically, the line rejection is 120 dB at 1 kHz; and the load regulation is better than 10 μ V for a 1A change. Temperature is the worst source of error; however, it is possible to achieve less than a 0.01% change in the output voltage over a -55°C to $+125^{\circ}\text{C}$ range.

The operation of both regulators is straightforward. An internal voltage reference is provided by a high-stability zener diode. The LM108A¹ operational amplifier compares a fraction of the output voltage with reference. In the positive regulator, the output of the op amp controls the ground terminal of an LM109² regulator through source follower, Q₁. Frequency compensation for the regulator is provided by both the R₁ C₂ combination and output capacitor, C₃.

The negative regulator shown in *Figure 2* operates similarly, except that discrete transistors are used for the pass element. A transistor, Q₁, level shifts the output of the LM108 to drive output transistors, Q₃ and Q₄. Current limiting is provided by Q₂. Capacitors C₃ and C₄ frequency compensate the regulator.

In the positive regulator the use of an LM109 instead of discrete power transistors has several advantages. First, the LM109 contains all the biasing and current limit circuitry needed to supply a 1A load. This simplifies the regulator. Second, and probably most important, the LM109 has thermal overload protection, making the regulator virtually burn-out proof. If the power dissipation becomes excessive or if there is inadequate heat sinking, the LM109 will turn off when the chip temperature reaches 175°C, preventing the device from being destroyed. Since no such device is available for use in the negative regulator, the heat sink should be large enough to keep the junction temperature of the pass transistors at an acceptable level for worst case conditions of maximum ambient temperature, maximum input voltage and shorted output.

Although the regulators are relatively simple, some precautions must be taken to eliminate possible problems. A solid tantalum output capacitor must be used. Unlike electrolytics, solid tantalum capacitors have low internal impedance at high frequencies. Low impedance is needed both for frequency compensation and to eliminate possible minor loop oscillations. The power transistor recommended for the negative regulator is a single-diffused wide-base device. This transistor type has fewer oscillation problems than double diffused transistors. Also, it seems less prone to failure under overload conditions.

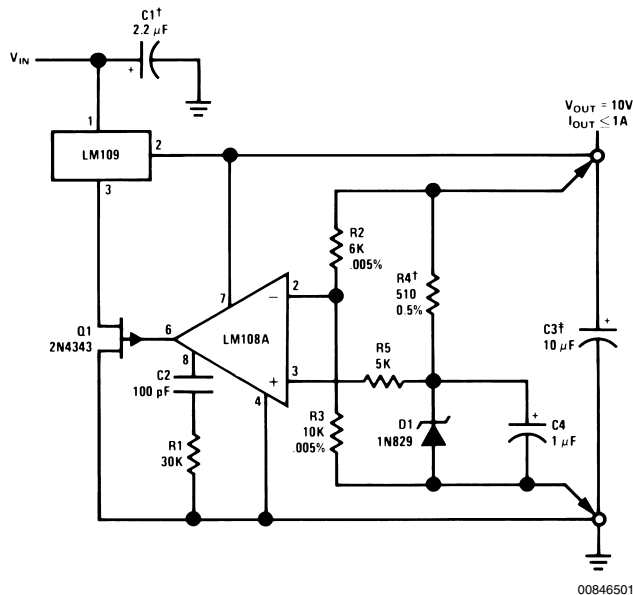

†Determines zener current. May be adjusted to minimize thermal drift.

‡Solid tantalum

FIGURE 1. High Stability Positive Regulator

Some unusual problems are encountered in the construction of a high stability regulator. Component choice is most important since the resistors, amplifier and zener can contribute to temperature drift. Also, good circuit layout is needed to eliminate the effect of lead drops, pickup, and thermal gradients.

The resistors must be low-temperature-coefficient wire-wound or precision metal film. Ordinary 1% carbon film, tin

oxide or metal film units are not suitable since they may drift as much as 0.5% over temperature. The resistor accuracy need not be 0.005% as shown in the schematic; however, they should track better than 1 ppm/°C. Additionally, wire-wound resistors usually have lower thermoelectric effects than film types. The resistor driving the zener is not quite as critical; but it should change less than 0.2% over temperature.

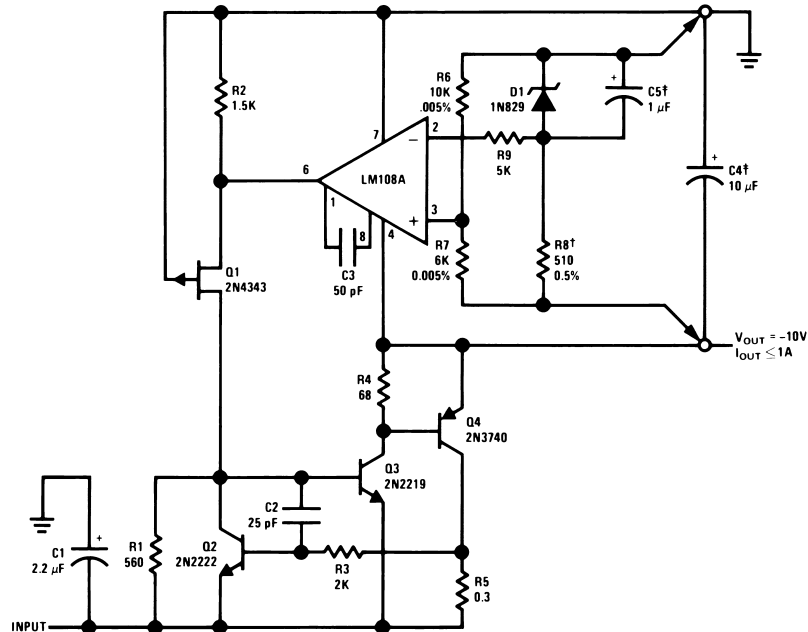

00846502

†Determines zener current. May be adjusted to minimize thermal drift.

‡Solid tantalum

FIGURE 2. High Stability Negative Regulator

The excellent dc characteristics of the LM108A make it a good choice as the control amplifier. The offset voltage drift of less than 5 $\mu\text{V}/^\circ\text{C}$ contributes little error to the regulator output. Low input current allows standard cells to be used for the voltage reference instead of a reference diode. Also the LM108 is easily frequency compensated for regulator applications.

Of course, the most important item is the reference. The 1N829 diode is representative of the better zeners available. However, it still has a temperature coefficient of 0.0005%/°C or a maximum drift of 0.05% over a -55°C to $+125^\circ\text{C}$ temperature range. The drift of the zener is usually linear with temperature and may be varied by changing the operating current from its nominal value of 7.5 mA. The temperature coefficient changes by about 50 $\mu\text{V}/^\circ\text{C}$ for a 15% change in operating current. Therefore, by adjusting the zener current, the temperature drift of the regulator may be minimized.

Good construction techniques are important. It is necessary to use remote sensing at the load, as is shown on the schematics. Even an inch of wire will degrade the load regulation. The voltage setting resistors, zener, and the amplifier should also be shielded. Board leakages or stray capacitance can easily introduce 100 μV of ripple or dc error into the regulator. Generally, short wire length and single-point grounding are helpful in obtaining proper operation.

References

1. R.J. Widlar, "IC Op Amp Beats FETs on Input Current," *National Semiconductor AN-29*, December, 1969.
2. R.J. Widlar, "New Developments in IC Voltage Regulators," in *1970 International Solid-State Circuits Conference Digest of Technical Papers*, Vol. XIII, pp. 158–159.

Notes

LIFE SUPPORT POLICY

NATIONAL'S PRODUCTS ARE NOT AUTHORIZED FOR USE AS CRITICAL COMPONENTS IN LIFE SUPPORT DEVICES OR SYSTEMS WITHOUT THE EXPRESS WRITTEN APPROVAL OF THE PRESIDENT AND GENERAL COUNSEL OF NATIONAL SEMICONDUCTOR CORPORATION. As used herein:

1. Life support devices or systems are devices or systems which, (a) are intended for surgical implant into the body, or (b) support or sustain life, and whose failure to perform when properly used in accordance with instructions for use provided in the labeling, can be reasonably expected to result in a significant injury to the user.
2. A critical component is any component of a life support device or system whose failure to perform can be reasonably expected to cause the failure of the life support device or system, or to affect its safety or effectiveness.



National Semiconductor Corporation
Americas
Email: support@nsc.com

www.national.com

National Semiconductor Europe

Fax: +49 (0) 180-530 85 86
Email: europe.support@nsc.com
Deutsch Tel: +49 (0) 69 9508 6208
English Tel: +44 (0) 870 24 0 2171
Français Tel: +33 (0) 1 41 91 8790

National Semiconductor Asia Pacific Customer Response Group

Tel: 65-2544466
Fax: 65-2504466
Email: ap.support@nsc.com

National Semiconductor Japan Ltd.

Tel: 81-3-5639-7560
Fax: 81-3-5639-7507