

Isolation Techniques For Signal Conditioning

National Semiconductor
Application Note 298
May 1982



Isolation Techniques For Signal Conditioning

AN-298

Industrial environments present a formidable challenge to the electronic system designer. In particular, high electrical noise levels and often excessive common mode voltages make safe, precise measurement difficult. One of the best ways to overcome these problems is by the use of isolated measurement techniques. Typically, these approaches utilize transformers or opto isolators to galvanically isolate the input terminals of the signal conditioning amplifier from its output terminal. This breaks the common ground connection and eliminates noise and dangerous common mode voltages. The conflicting requirements for good accuracy and total input/output galvanic isolation requires unusual circuit techniques. A relatively simple isolated signal conditioner appears in *Figure 1*.

to 45kHz \pm .25dB with the -3dB point beyond 85kHz. Rise-time is about 10 microseconds. *Figure 3* shows the motor waveform at the ground referenced circuit output. The isolated, wideband response of the circuit permits safe monitoring of the fast rise SCR turn-on as well as the motor's brush noise.

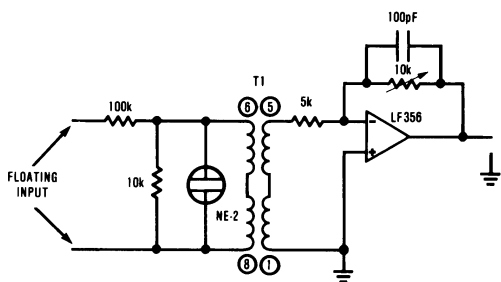

OUTPUT= INPUT \div 100 & ISOLATED T1=UTC #P2
TO AC LINE FROM FULL WAVE BRIDGE
FIGURE 1.

FLOATING INPUT HIGH VOLTAGE MOTOR MONITOR

In this inexpensive circuit, a wideband audio transformer permits safe, ground referenced monitoring of a motor which is powered directly from the 115VAC line. *Figure 2* details the measurement arrangement. The floating amplifier inputs are applied directly across the brush-type motor. The 100k-10k string, in combination with the transformer ratio, provides a nominal 100:1 division in the observed motor voltage while simultaneously allowing a ground referenced output. The NE-2 bulb suppresses line transients while the 10k potentiometer trims the circuit for a precise 100:1 scale factor. To calibrate the circuit, apply a 10-volt RMS 1kHz sine wave to the floating inputs, and adjust the potentiometer for 100 millivolts RMS output. Full power bandwidth extends from 15Hz

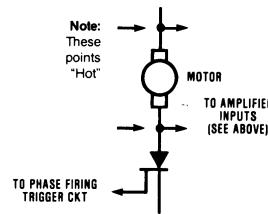

AC LINE FROM FULL WAVE BRIDGE
FIGURE 2.

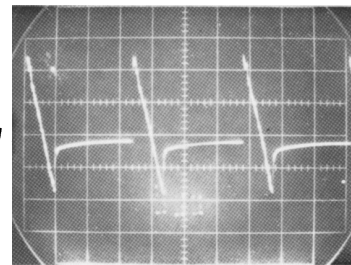

FIGURE 3.

ISOLATED TEMPERATURE MEASUREMENT

Figure 4 shows a scheme which allows an LM135 temperature sensor to operate in a fully floating fashion. In this circuit, the LM311 puts out a 100 microsecond pulse at about 20Hz. This signal biases the PNP transistor, whose collector load is composed of the 1k Ω unit and the primary of T1. The voltage that develops across T1's primary (waveform A, *Figure 5*) will be directly dependent upon the value that the LM135 temperature sensor clamps the secondary at. Waveform B, *Figure 5* details the transformer primary current.

AN-298

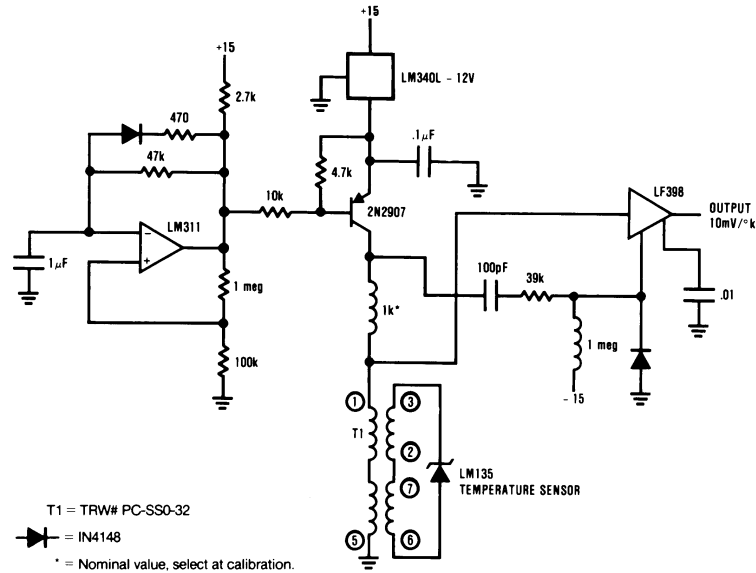
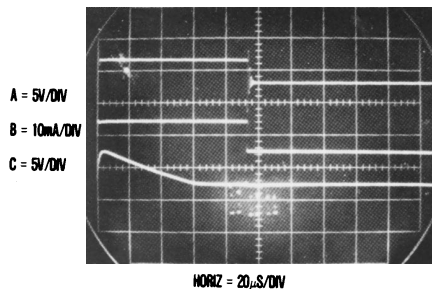

FIGURE 4.

AN005639-4

This voltage value, of course, varies with the temperature of the LM135 in accordance with its normal mode of operation. The LF398 sample-and-hold IC is used to sample the transformer primary voltage and presents the circuit output as a DC level. The 100 pF-39k-1MΩ combination presents a trigger pulse (waveform C, Figure 5) to the LF398, so that the sampling period does not finish until well after the LM135 has settled. The LM340 12-volt regulator provides power supply rejection for the circuit. To calibrate, replace the LM135 with an LM336 2.5-volt diode of known breakdown potential. Next, select the 1kΩ valve until the circuit output is the same as the LM336 breakdown voltage. Replace the LM336 with the LM135 and the circuit is ready for use.



AN005639-5

FIGURE 5.

FULLY ISOLATED PRESSURE TRANSDUCER MEASUREMENT

Strain gauge-based transducers present special difficulties if total isolation from ground is required. They need excitation power in addition to their output signal. Some industrial measurement situations require that the transducer must be physically connected to a structure which is floating at a high common mode voltage. This means that the signal conditioning circuitry must supply fully floating drive to the strain gauge bridge, while also providing isolated transducer output signal amplification. Figure 6 details a way to accomplish this. Here, the strain bridge is excited by a transformer which generates a pulse of servo-controlled amplitude. The pulse is generated by storing the sampled amplitude of the output pulse as a DC level, and supplying this information to a feedback loop which controls the voltage applied to the output switch. A2 functions as an oscillator which simultaneously drives Q2-Q3 and the LF398 (A3) sample mode pin. When A2's output pulse ends, A3's output is a DC level equal to the amplitude of the output pulse which drives the strain bridge. The dual secondary of T1 allows accurate magnetic sampling of the strain bridge output pulse without sacrificing electrical isolation. A3's output is compared to the LH0070 10-volt reference by A4, whose output drives Q1. Q1's emitter provides the DC supply level to the Q2-Q3 switch. This servo action forces the pulses applied to the strain gauge transducer (waveform A, Figure 7) to be of constant amplitude and equal to the 10-volt LH0070 reference output. Some amount of the pulse's energy is stored in the 100µF capacitor and used to power the LM358 dual (A1) followers. These devices unload the output of the transducer bridge and drive the primary of T2. T2's secondary output amplitude (waveform B, Figure 7) represents the transducer output value. This potential is amplified by A5 and fed to A6, a sample-and-hold circuit. A6's sample command is a shortened version of the A2 oscillator pulse. The 74C221 generates this pulse (waveform C, Figure 7).

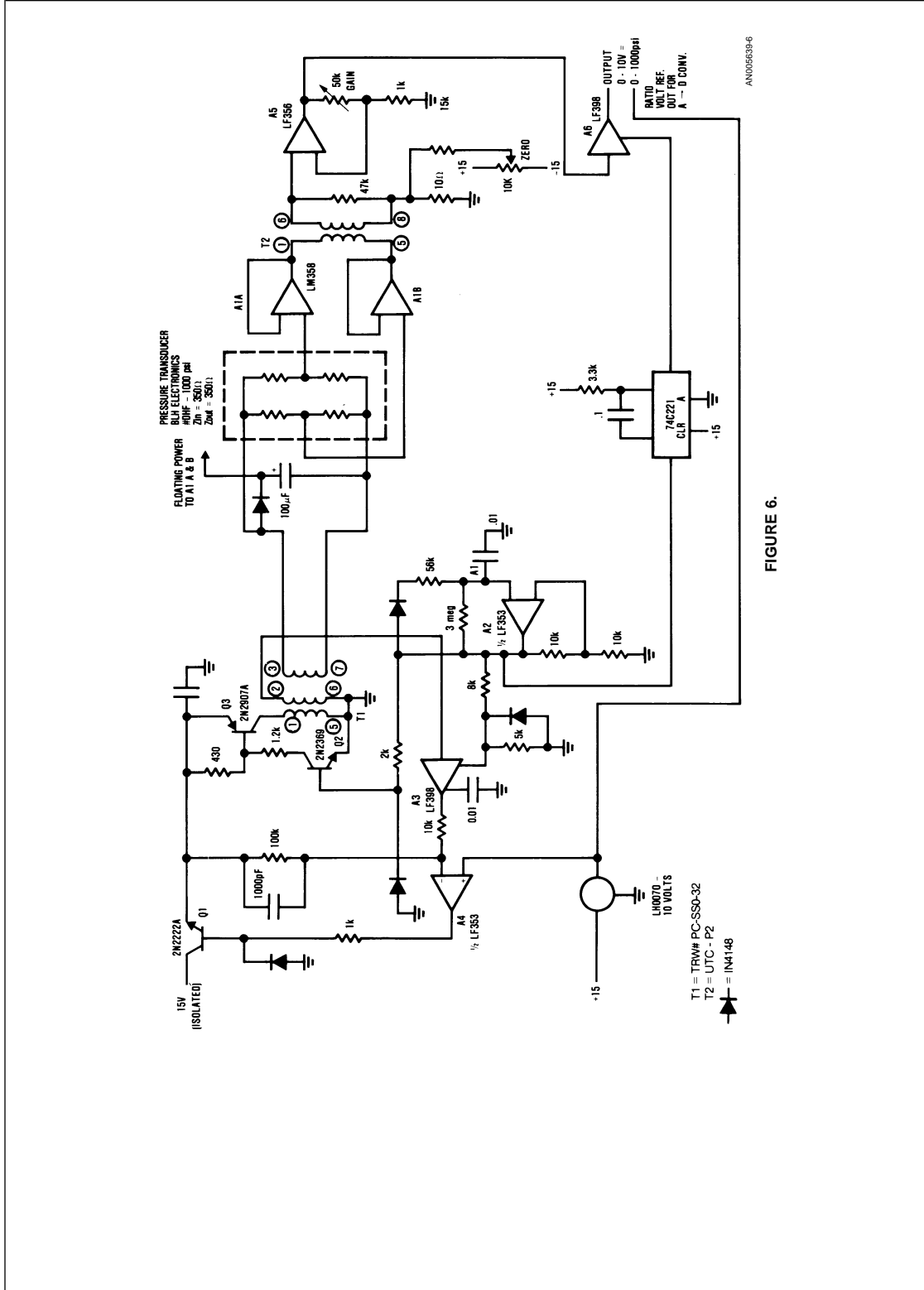

FIGURE 6.

AN005639-6

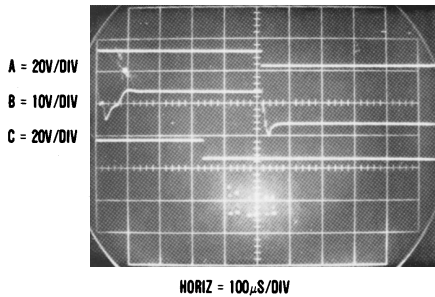

FIGURE 7.

Because the A6 sample command falls during the settled section of T2's output pulse, A6's output will be a DC representation of the amplified strain gauge pressure transducer output. The LH0070 output may be used to ratiometrically reference a monitoring A/D converter. To calibrate this circuit, insert a strain bridge substitution box (e.g., BLH model 625) in place of the transducer and dial in the respective values for zero and full-scale output (which are normally supplied

with the individual transducer). Adjust the circuit "zero" and "gain" potentiometers until a 0- to 10-volt output corresponds to a 0 to 1000psi pressure input.

1.5-VOLT POWERED ISOLATED PRESSURE MEASUREMENT

Figure 8 diagrams another pressure measurement circuit. This circuit presents a frequency output which is fully isolated by the transformer indicated. The entire circuit may be powered from a 1.5-volt supply, which may be derived from a battery or solar cells. The potentiometer output of the pressure transducer used is fed to a voltage-to-frequency converter circuit. In this V-F circuit, an LM10 op amp acts as an input amplifier, and forces the collector current of Q1 to be linearly proportional to V_{IN} for a range of 0 to +400 millivolts. Likewise, the reference amplifier of the LM10 causes Q2's output current to be stable and constant under all conditions. The transistors Q3-Q10 form a relaxation oscillator, and every time the voltage across C1 reaches 0.8-volt, Q6 is commanded to reset it to zero volts differential. This basic circuit is not normally considered a very accurate technique, because the dead time, while Q6 is saturated, will cause a large (1% nonlinear) in the V-to-F transfer curve. However, the addition of R_x causes the reference current flowing through Q2 to include a term which is linearly proportional to the signal, which corrects the transfer nonlinearity.

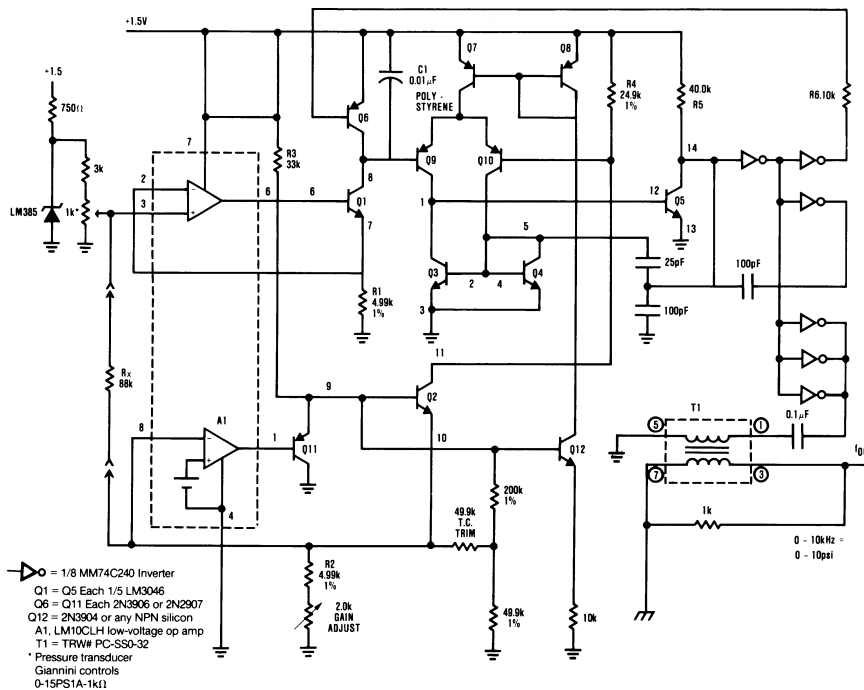

the resistor to 20k. If f is too slow/hot, add more resistance in series with the 49.9k. Total current drain for this circuit is about 1 milliampere.

FULLY ISOLATED "ZERO POWER" COMPLETE A/D CONVERTER

Figure 9 shows a complete 8-bit A/D converter, which has all input and output lines fully floating from system ground. In addition, the A/D converter requires no power supply for operation! Circuit operation is initiated by applying a convert-command pulse to the "convert-command" input (trace A, Figure 11). This pulse simultaneously forces the "Data Output" line low (trace B, Figure 11) and propagates across the isolation transformer. The pulse appears at the transformer secondary (Figure 10, trace A) and charges the 100 μ F capacitor to five volts. This potential is used to supply power to the floating A/D conversion circuitry. The pulse appearing at the transformer secondary is also used to start the A/D conversion by biasing comparator A's negative input low. This causes comparator A's output to go low, discharging the .06 μ F capacitor (waveform B, Figure 10). Simultaneously, the 10kHz oscillator (Figure 10, trace D), formed by comparator D and its associated components, is forced off via the 22k diode path. A second diode path also forces comparator D's output low (Figure 10, trace E). Note the cessa-

tion of oscillation during the time the convert command pulse is high. When the convert command pulse falls, the Q1-Q2 current source begins to charge the .06 μ F capacitor. During this time, the 10 kHz comparator C oscillator runs, and comparator D's output is a stream of 10 kc clock pulses. When the ramp (trace B, Figure 10) across the .06 μ F capacitor exceeds the circuit input voltage, comparator B's output goes high (trace C, Figure 10), forcing comparator D's output low. The number of pulses which appeared at comparator D's output is directly proportional to the value of the circuit's input voltage. These pulses are amplified by the two NPN transistors which are used to modulate the data pulse stream back across the transformer. The six series diodes insure that the modulated data does not appear at comparator A's input and trigger it. The pulses appear at the primary (Figure 11, trace A) as small amplitude spikes and are then amplified by the data output transistor, whose collector waveform is trace B or Figure 11. In this example a 0- to 3-volt input produces 0- to 300 pulses at the output. The 22k diode path averts a +1 count uncertainty error by synchronizing the 10kHz clock to the conversion sequence at the beginning of each conversion. The 500k potentiometer in the current source adjusts the scale factor. The circuit drifts less than 1LSB over 25°C \pm 20°C and requires 45 milliseconds to complete a full scale 300 count conversion.

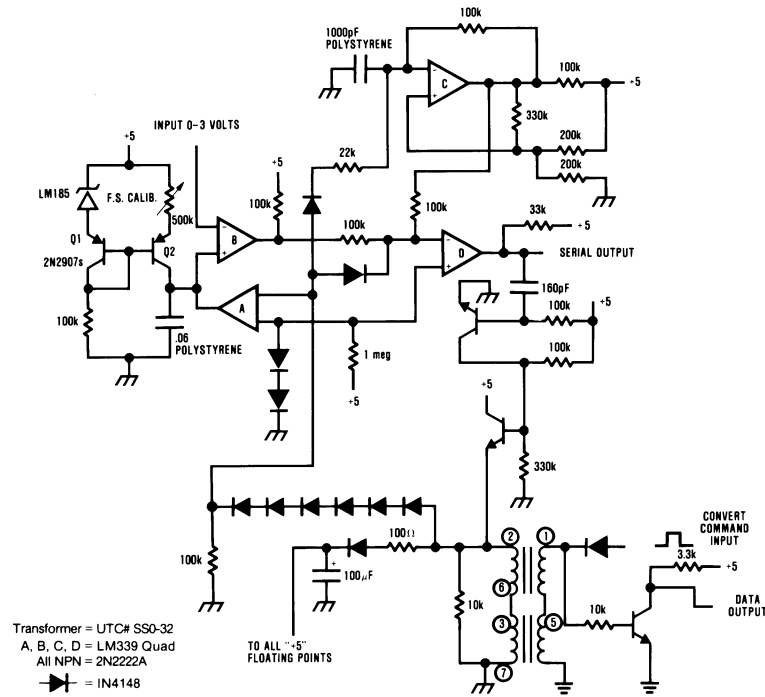

FIGURE 9.

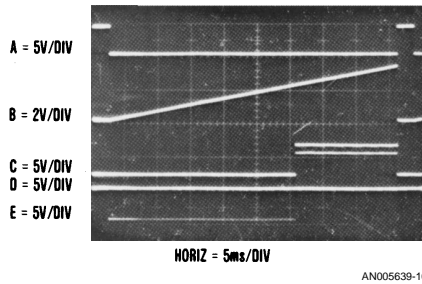

FIGURE 10.

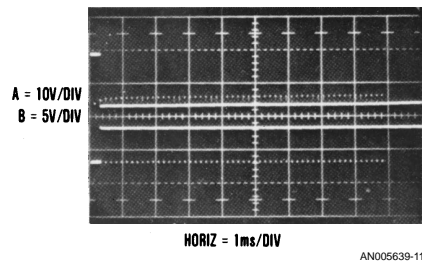

FIGURE 11.

COMPLETE, FLOATING MULTIPLEXED THERMOCOUPLE TEMPERATURE MEASUREMENT

Figure 12 shows a complete, fully floating multiplexed thermocouple measurement system. Power to the floating system is supplied via T2, which runs in a self oscillating DC-DC converter configuration with the 2N2219 transistors. T2's output is rectified, filtered, and regulated to ± 15 volts. An eight channel LF13509 multiplexer is used to sequentially switch 7 inputs and a ground reference into the LM11 amplifier. The LM11 provides gain and cold junction compensation for the thermocouples. The multiplexer is switched from the 74C93 counter, which is serially addressed via the 4N28 opto isolator. The ground referenced channel prevents monitoring instrumentation from losing track of the multiplexer state. The LM11's output is fed into a unity gain isolation amplifier. Oscillator drive for the isolation amplifier is derived by dividing down T2's pulsed output, and shaping the 74C90's output with A4 and its associated components. This scheme also prevents unwanted interaction between the T2 DC-DC converter and the isolation amplifier. This circuit, similar to the servo-controlled amplitude pulser described in Figure 6, puts a pulse across T1's primary. The amplitude of the pulse is directly dependent on the LM11's output value. T1's secondary receives the pulse and feeds into an LF398 sample-and-hold-amplifier. The LF398 is supplied with a delayed trigger pulse, so that T1's output is sampled well after settling occurs. The LF398 output equals the value of the LM11. In this fashion, the fully floating thermocouple information may be connected to grounded test equipment or computers. Effective cold-junction compensation results when the thermocouple leads and the LM335 are held isothermal. To calibrate the circuit, first adjust R3 for an LM11 gain of 245.7. Next, short the "+" input of the LM11 and the LM329 to floating common, and adjust R1 so that the circuit output is 2.982 volts at 25°C. Then, remove the short across the LM329 and adjust R2 for a circuit output of 246 millivolts at 25°C. Finally, remove the short at the LM11 input, and the circuit is ready for use.

Book
Extract
End

LIFE SUPPORT POLICY

NATIONAL'S PRODUCTS ARE NOT AUTHORIZED FOR USE AS CRITICAL COMPONENTS IN LIFE SUPPORT DEVICES OR SYSTEMS WITHOUT THE EXPRESS WRITTEN APPROVAL OF THE PRESIDENT OF NATIONAL SEMICONDUCTOR CORPORATION. As used herein:

1. Life support devices or systems are devices or systems which, (a) are intended for surgical implant into the body, or (b) support or sustain life, and whose failure to perform when properly used in accordance with instructions for use provided in the labeling, can be reasonably expected to result in a significant injury to the user.
2. A critical component in any component of a life support device or system whose failure to perform can be reasonably expected to cause the failure of the life support device or system, or to affect its safety or effectiveness.

 **National Semiconductor Corporation**
Americas
Tel: 1-800-272-9959
Fax: 1-800-737-7018
Email: support@nsc.com

National Semiconductor Europe
Fax: +49 (0) 1 80-530 85 86
Email: europe.support@nsc.com
Deutsch Tel: +49 (0) 1 80-530 85 85
English Tel: +49 (0) 1 80-532 78 32
Français Tel: +49 (0) 1 80-532 93 58
Italiano Tel: +49 (0) 1 80-534 16 80

National Semiconductor Asia Pacific Customer Response Group
Tel: 65-2544466
Fax: 65-2504466
Email: sea.support@nsc.com

National Semiconductor Japan Ltd.
Tel: 81-3-5620-6175
Fax: 81-3-5620-6179

www.national.com

National does not assume any responsibility for use of any circuitry described, no circuit patent licenses are implied and National reserves the right at any time without notice to change said circuitry and specifications.