

An Acoustic Transformer Powered Super-High Isolation Amplifier

National Semiconductor
Application Note 285
October 1981



A number of measurements require an amplifier whose input terminals are galvanically isolated from its output and power terminals. Such devices, often called parametric or isolation amplifiers, are employed in situations that call for measurements in the presence of high common-mode voltages or require complete ground path isolation for safety reasons. Although commercial devices are available to meet these needs, the method of power transfer used to supply power to the floating input circuitry has limited the common-mode voltage capability to about 2500V. In addition, leakage currents can run as high as 2 μ A.

Present devices (*Figure 1*) employ transformers to transmit power to the floating front end of the amplifier. The output of the floating amplifier is then modulated onto a carrier which is transmitted via a transformer or opto-isolator to the output of the amplifier. Modulation schemes employed include pulse width and pulse amplitude as well as frequency and light intensity coding. The limitation on common-mode voltage breakdown and leakage in this type of device is the breakdown rating of the transformers employed. Even when opto-isolators are used to transmit the modulated signal, the requirement for power to run the floating front end mandates the need for at least one transformer in the amplifier.

Although other methods of transmitting electrical energy with high isolation are available (e.g., microwaves, solar cells) they are expensive, inefficient and impractical. Batteries present and obvious choice but have drawbacks due to maintenance and reliability. What is really needed to achieve extremely high common-mode capability and low leakage is a method for transferring electrical energy which is relatively efficient, easy to implement and offers almost total input-to-input isolation.

ACOUSTIC TRANSFORMERS

A technique which satisfies the aforementioned requirements is available by taking advantage of the piezoelectric characteristics of certain ceramic materials. Although piezoelectric materials have long been recognized as electrical-to-acoustic or acoustic-to-electrical transducers (e.g., buzzers and microphones) their capability for electrical-to-acoustic-to-electrical energy conversion has not been employed. This technique, which capitalizes on the non-conducting nature of ceramic materials, is the key to a super-high isolation electrical transformer. In this device the conventional transformer's transmission medium of magnetic flux and conductive core material is replaced by acoustic waves and a non-conducting piezoceramic core. *Figure 2* shows a photograph of typical acoustic transformers, fabricated by Channel Industries, Santa Barbara, California. Two physical configurations are shown, although many are possible. In each case the transformer is constructed by simply bonding a pair of leads to each end of the piezoceramic material. Insulation resistance exceeds $10^{12}\Omega$ and primary-to-secondary capacitance is typically a few pF. The nature of the piezoceramic material employed and the specific physical configuration determines the resonant frequency of the transformer. *Figure 3* shows a plot of the output of an acoustic transformer driven at resonance. From the data it can be seen that transfer efficiency can exceed 75%, depending upon loading conditions. Output short circuit current for the device tested was 35 mA.

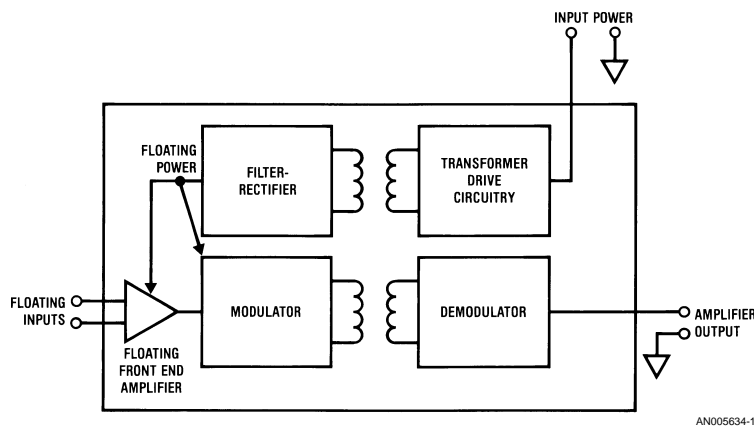

FIGURE 1.

APPLYING THE TRANSFORMER—A 20,000V ISOLATION AMPLIFIER

Figure 4 shows a basic but working design for an isolation amplifier using the acoustic transformer. This design will easily stand off common-mode voltages of 20,000V and

versions that operate at 100 kV potentials have been constructed. In this design the acoustic transformer's HI-Q characteristics are used to allow it to self resonate in a manner similar to a quartz crystal. This eliminates the requirement to drive the transformer with a stable oscillator.

The Q1 configuration provides excitation to the transformer primary, while the diodes and capacitor rectify and filter the secondary's output. *Figure 5* shows the collector waveform at Q1 (Trace A) while Trace B, *Figure 5* shows the secondary output. Despite the distorted drive waveform the transformer's secondary output is a clean sinusoid because of the extremely Hi-Q of the device. An LM331 V/F converter is used to convert the amplitude input to a frequency output. The V/F output drives an LED, whose output is coupled to a length of fiber-optic cable. Trace A, *Figure 6* shows the LM331's output, while Trace B indicates the current through the LED. Each time the LM331 output goes low, a short 20 mA current spike is passed through the LED via the 0.01 μ F capacitor. Because the duty cycle is low, the average current out of the transformer's secondary is small and power re-

quirements are minimized. At the amplifier output a photodiode is used to detect the light encoded signal and another LM331 serves as an F/V converter to demodulate the frequency encoded signal.

APPLICATIONS

An excellent application for the high isolation amplifier is shown in *Figure 7*. Here, the winding temperature of an electric utility transformer operating at 10,000V is monitored by the LM135 temperature transducer. The LM135 output biases the isolation amplifier input and the temperature information comes out at the amplifier output, safely referenced to ground.

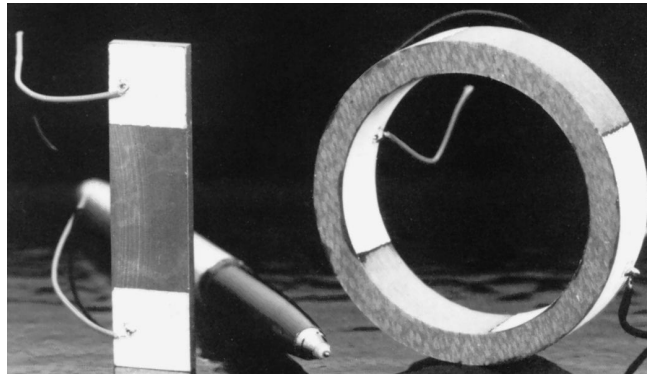

AN005634-2

FIGURE 2.

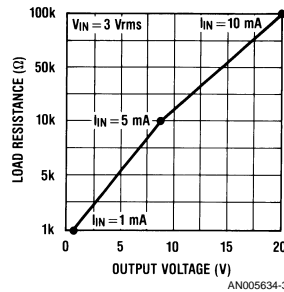

AN005634-3

FIGURE 3.

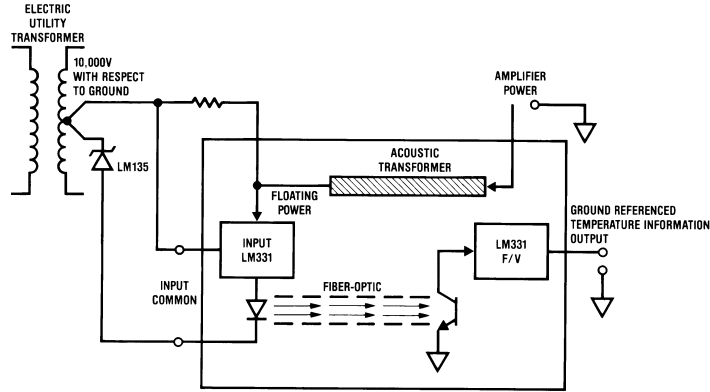

AN005634-7

FIGURE 7.

Figure 8 shows another application where the high common-mode voltage capability allows a 5000V regulated power supply to have a fully floating output. Here, a push-pull type DC-DC converter generates the 5 kV output. The piezo-isolation amplifier provides a ground referenced output feedback signal to A1, which controls the transformer drive, completing a feedback loop.

In Figure 9, the piezo-isolation amplifier is used to provide complete and fail-safe isolation for the inputs of a piece of test equipment to be connected into a CMOS IC production line. This capability prevents any possibility of static discharge damage, even when the equipment may have accumulated a substantial charge.

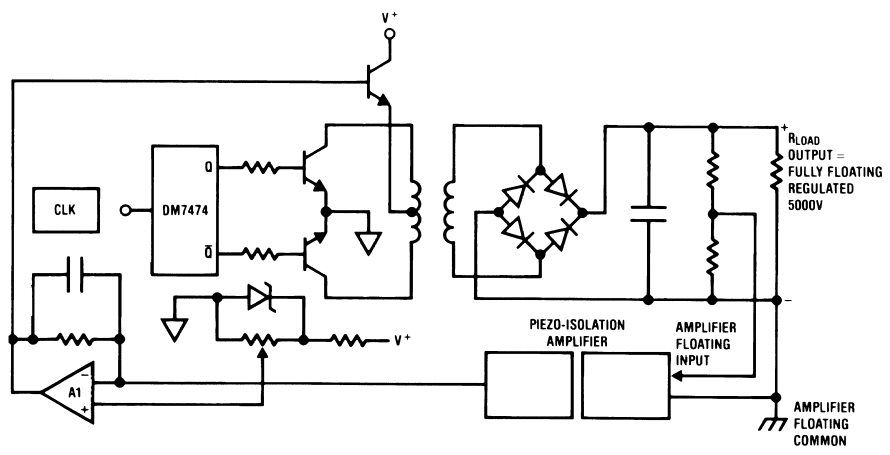

AN005634-9

FIGURE 8.

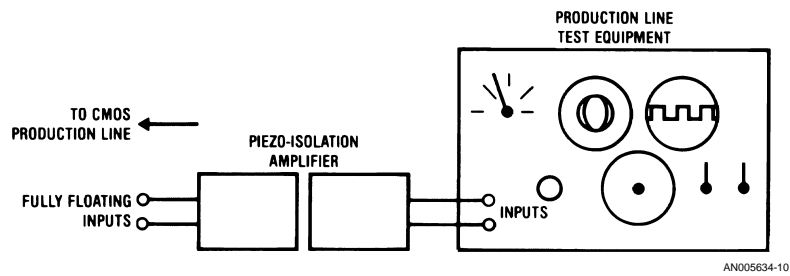

FIGURE 9.

Book
Extract
End

Notes

LIFE SUPPORT POLICY

NATIONAL'S PRODUCTS ARE NOT AUTHORIZED FOR USE AS CRITICAL COMPONENTS IN LIFE SUPPORT DEVICES OR SYSTEMS WITHOUT THE EXPRESS WRITTEN APPROVAL OF THE PRESIDENT AND GENERAL COUNSEL OF NATIONAL SEMICONDUCTOR CORPORATION. As used herein:

1. Life support devices or systems are devices or systems which, (a) are intended for surgical implant into the body, or (b) support or sustain life, and whose failure to perform when properly used in accordance with instructions for use provided in the labeling, can be reasonably expected to result in a significant injury to the user.
2. A critical component is any component of a life support device or system whose failure to perform can be reasonably expected to cause the failure of the life support device or system, or to affect its safety or effectiveness.

 <p>National Semiconductor Corporation Americas Email: support@nsc.com</p> <p>www.national.com</p>	<p>National Semiconductor Europe</p> <p>Fax: +49 (0) 180-530 85 86 Email: europe.support@nsc.com</p> <p>Deutsch Tel: +49 (0) 69 9508 6208 English Tel: +44 (0) 870 24 0 2171 Français Tel: +33 (0) 1 41 91 8790</p>	<p>National Semiconductor Asia Pacific Customer Response Group</p> <p>Tel: 65-2544466 Fax: 65-2504466 Email: ap.support@nsc.com</p>	<p>National Semiconductor Japan Ltd.</p> <p>Tel: 81-3-5639-7560 Fax: 81-3-5639-7507</p>
--	--	--	--

National does not assume any responsibility for use of any circuitry described, no circuit patent licenses are implied and National reserves the right at any time without notice to change said circuitry and specifications.