

## Designing with a New Super Fast Dual Norton Amplifier

National Semiconductor  
Application Note 278  
Timothy T. Regan  
September 1981



### WHY ANOTHER NORTON AMPLIFIER?

The current differencing Norton amplifier has been widely applied over the last 5 years because of the versatility and availability of quad Norton amplifiers (the LM3900). These low cost quads are found today in a wide variety of analog systems, but primarily in medium frequency and single supply AC applications. Today, a brand new dual current differencing amplifier, the LM359, offers spectacular speed improvements which can be used in circuits operating well beyond the video frequencies.

**How the speed is improved:** The speed improvement of the new Norton amplifier is due to the cascode circuit (Figure 1). Cascode circuits are used in high frequency single-ended amplifier designs because there is no Miller effect on the collector-to-base capacitance of the input transistor. Also, there is no collector-to-emitter parasitic feedback in the common base configured transistor, Q2, so the high frequency signal appearing at the output of the cascode does not reflect back into the input. Furthermore, note that band-limiting PNP transistors are eliminated from the signal path; here PNPs are used only for collector loads, so not only is high speed maintained, but high gain is also obtained without additional amplification stages.

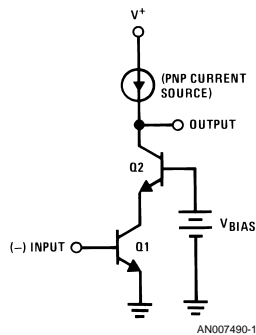

FIGURE 1. Basic Cascode Circuit

**Adding a mirror to get differential inputs:** To make the high frequency single-ended amplifier more versatile differential inputs should be provided. An easy way is to add a current mirror across the negative (inverting) input terminal (Fig-

ure 2). This method provides current differencing, as the current entering the non-inverting input is extracted from the inverting input current. The LM359 is then a current differencing, as opposed to a voltage differencing, op amp.

**The programmable features extend versatility:** An additional feature of the LM359 is the programmability of its speed, its input impedance, and its output current sinking capability for line driver applications and for control of overall power consumption (Figure 3). An internal compensation capacitor is adequate compensation for all inverting applications where the gain is 10 or higher. An additional compensation capacitor can be added externally to reduce undesired bandwidth or to fit any particular application, as will be discussed later. The following sections illustrate some new design ideas using this fast Norton amplifier.

### A NEW HIGH FREQUENCY ACTIVE FILTER STRUCTURE

Multiple op amp active filter building blocks are very popular because of their low sensitivities and their tunability. The basic element of such a filter is the inverting integrator. Usually two inverting integrators are cascaded and a third inverter allows closing the overall loop with the proper phase. This is the idea behind the state variable and bi-quad filter structures which today are fully available in low cost hybrid forms.

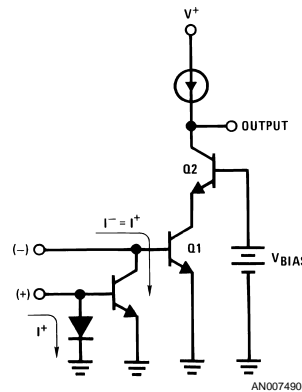

FIGURE 2. Adding a Current Mirror to Provide Current Differencing Inputs

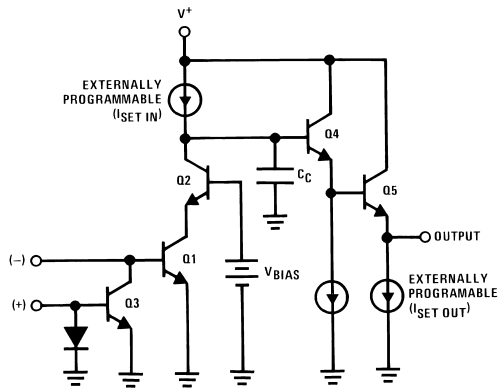

FIGURE 3. A Simplified Schematic of the LM359, a High Speed, Current Differencing Amplifier. The Input, Output and Speed Characteristics are Externally Programmable.

The op amp count in these filters could be reduced by one (allowing use of a dual op amp instead of 3 op amps or a quad) if a true non-inverting integrator could be built with a single op amp. Unfortunately, this cannot be done with standard op amps but is a trivial task with current differencing amplifiers (Figure 4). Combining a non-inverting integrator with an inverting one, a new high frequency and low sensitivity active filter building block can be made (Figure 5). Table 1 shows the 3 particular filter structures, together with their design equations, which are derived from Figure 5. The frequency compensation for the 2 amplifiers is asymmetric to optimize performance. Also, since the LM359 is a wide bandwidth amplifier, high frequency circuit layout is strongly recommended. The circuit works with a single supply, and the output DC biasing of each filter type is provided with 2 resistors, R1 and Rb, which should be chosen according to Table 2.

TABLE 1. Analysis and Design Equations

Type	V <sub>O1</sub>	V <sub>O2</sub>	C <sub>i</sub>	R <sub>i2</sub>	R <sub>i1</sub>	f <sub>o</sub>	Q <sub>o</sub>	f <sub>z</sub> (Notch)	H <sub>o</sub> (LP)	H <sub>o</sub> (BP)	H <sub>o</sub> (HP)
I	BP	LP	O	R <sub>i2</sub>	∞	$\frac{1}{2\pi RC}$	$\frac{R_Q}{R}$	-	$\frac{R}{R_{i2}}$	$\frac{R_Q}{R_{i2}}$	-
II	HP	BP	C <sub>i</sub>	∞	∞	$\frac{1}{2\pi RC}$	$\frac{R_Q}{R}$	-	-	$\frac{R_Q C_i}{RC}$	$\frac{C_i}{C}$
III	Notch or Band-Reject	-	C <sub>i</sub>	∞	R <sub>i1</sub>	$\frac{1}{2\pi RC}$	$\frac{R_Q}{R}$	$\frac{1}{2\pi R R_i C C_i}$	-	-	$\frac{C_i}{C}$ as f → ∞ $\frac{R}{R_1}$ as f → 0

TABLE 2. DC Biasing Equations for V<sub>O1</sub> (DC) ≅ V<sub>O2</sub> (DC) ≅ V<sup>+</sup>/2

Type I	$\frac{2 V_{IN} (DC)}{V^+ (R_{i2})} + \frac{1}{R} + \frac{1}{R_Q} = \frac{2}{R_b}; R_1 = 2R$
Type II	$\frac{1}{R} + \frac{1}{R_Q} = \frac{2}{R_b}; R_1 = 2R$
Type III	$\frac{1}{R} + \frac{1}{R_Q} = \frac{2}{R_b}; \frac{1}{R_1} = \frac{V_{IN} (DC)}{V^+ (R_{i1})} + \frac{1}{2R}$

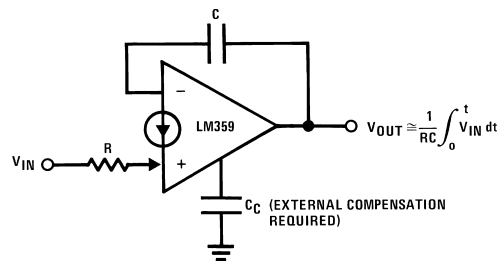
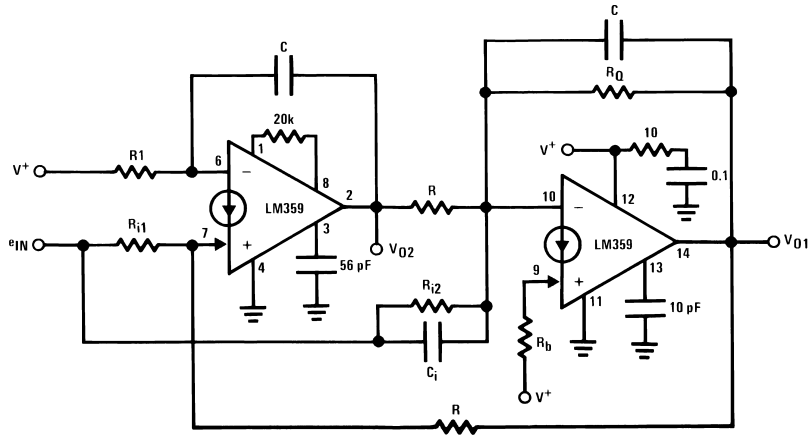

FIGURE 4. A True Non-Inverting Integrator



AN007490-5

Tables 1, 2 relate to Figure 5

**FIGURE 5. High Performance 2 Amplifier Bi-Quad Filter. Half of the LM359 Acts as a Non-Inverting Integrator and the Other Half Acts as an Inverting One. No Extra Inversion is Necessary to Provide Proper Phase.**

The operating range of an active filter can be estimated by comparing its  $Q_o$ , center frequency product ( $f_o \times Q_o$ ), with the gain bandwidth product (GBW) of its active elements. The  $f_o \times Q_o$  should be less than the active element GBW by a factor of at least 20; a higher factor will yield less sensitive filters. For instance, with a 5 MHz op amp, the  $f_o \times Q_o$  product of the filter should not exceed 250 kHz, and in reality should be even less. The filters tested with the LM359 could extend their  $f_o \times Q_o$  product up to 2 MHz.

#### VOLTAGE-CONTROLLED LOW PASS FILTER

A most unique feature of the LM359 is that it provides the user with complete control of its frequency response over a very wide range. The combination of both programmable input stage current and external compensation capability is the key to this flexibility.

One of the most simple, yet illustrative, examples of the usefulness of this capability is the voltage-controlled low pass filter shown in Figure 6. The corner frequency of this filter is determined by the closed loop corner frequency of the inverting, gain of 100 amplifier. This frequency is directly controlled by the frequency of the dominant pole of the amplifier's open loop response, which can be approximated by the expression:

$$f_p \approx \frac{3 I_{SET IN}}{2 \pi C_{COMP} A_{VOL} V_T}$$

where  $A_{VOL}$  is the amplifier's DC open loop gain,  $V_T$  is equal to  $KT/q$  or 0.026V at room temperature,  $I_{SET IN}$  is the input stage programming current, and  $C_{COMP}$  is the total compensation capacitance.

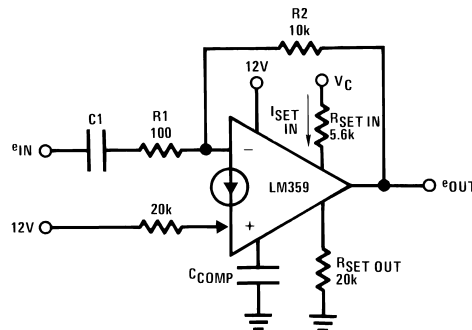

AN007490-6

**FIGURE 6. Voltage-Controlled Low Pass Filter. Minimum Input Frequency is Determined by C1 and R1.**

The closed loop corner frequency, which, as stated is also the corner frequency of the filter, is:

$$f_c = \beta \cdot GBW = \beta \cdot A_{VOL} \cdot f_p$$

where  $\beta$  is the feedback factor,  $R1/(R1+R2)$ , and a single pole open loop frequency response is assumed. Combining these two expressions, the corner frequency is:

$$f_c = \frac{3 I_{SET IN} \cdot \beta}{2 \pi C_{COMP} V_T}$$

The simplest method to dynamically control  $f_c$  is to vary  $I_{SET IN}$  through a control voltage,  $V_C$ , where:

$$I_{SET IN} = \frac{V_C - V_{BE}}{R_{SET IN} + 500\Omega}$$

In this manner,  $C_{COMP}$  should be chosen for the highest desired corner frequency at maximum  $I_{SET IN}$ . Two curves illustrating the dependence of the corner frequency on  $I_{SET IN}$  for two different compensation capacitors are shown in *Figure 7*.

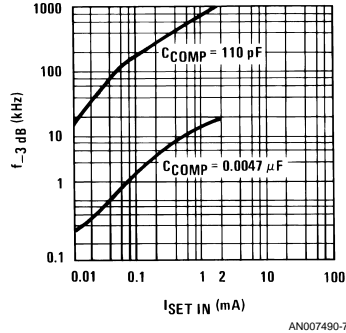

**FIGURE 7. Amplifier Closed Loop Corner Frequency vs  $I_{SET IN}$**

It should be noted that as the compensation capacitor is increased, or  $I_{SET IN}$  is decreased, the maximum slew rate of the amplifier is decreased. To prevent slew rate induced distortion of sinusoidal input signals, the following restriction applies:

$$\text{Slew rate max} = \frac{3 I_{SET IN}}{C_{COMP}} \geq \omega V_o \text{ peak},$$

where  $V_o$  peak is the peak output voltage of the filter and  $\omega$  is  $2\pi f_{IN}$ , where  $f_{IN}$  is the signal frequency. The output voltage for signal frequencies less than the corner frequency of the filter (within the passband) should then be restricted to:

$$V_o \text{ peak} \leq \frac{V_T}{\beta}$$

#### VIDEO AMPLIFIERS

The basic principle behind the design of the LM359 is to provide amplification of high frequency signals with the ease of using standard operational amplifiers. The most obvious application area for this amplifier is in the video area where a fair amount of gain is required at frequencies much higher than monolithic op amps can provide.

A specific application is the amplification or buffering of a composite video signal for a distributed monitor system.

*Figure 8* shows a typical connection for a non-inverting video amplifier whose signal source may be either detected video from a receiver, or possibly a camera signal. The output stage of the LM359 can be programmed, as shown, to drive a terminated  $75\Omega$  cable to  $4 V_p$ -p for use as a video line driver. For color signals, the differential phase error and differential gain error at 3.58 MHz are desirably low, as noted in *Table 3*.

**TABLE 3. Typical Video Amplifier Performance**

$A_v = 20 \text{ dB}$	
-3 dB Bandwidth $\rightarrow$	2.5 Hz to 25 MHz
Differential Phase Error $< 1^\circ$	at 3.58 MHz
Differential Gain Error $< 2\%$	at 3.58 MHz
Amplifier Output Swing =	4 Vp-p Max

For general purpose wideband amplifiers, the availability of two amplifiers in a single package allows cascading two gain stages to achieve very high gain bandwidth products as shown in *Figure 9*.

#### DISC AND MAGNETIC TAPE MEMORY SENSING

In digital data recovery from a magnetic storage medium, such as a disc or magnetic tape, there exists a need for high gain bandwidth amplifiers to convert the low level voltage transients from the output of the playback head (caused by a magnetic flux reversal on the tape or disc) to digital pulses that can be processed by data separating or decoding circuitry. The two amplifiers in a single LM359 package can be combined in a variety of ways to provide the basic blocks of a playback channel.

- For very high bit rates and low level signals they can be cascaded to optimize overall gain bandwidth product, as already shown in *Figure 9*.
- For single-ended playback signals (non center-tapped head), one amplifier can be used as a gain stage and the other as a differentiating stage to convert recovered signal peaks into bi-directional zero crossing signals, and then properly drive a comparator with regard to direction of flux changes on the disc or tape; this simplifies decoding of phase-encoded data.
- For differential playback signals (center-tapped head), one amplifier can be used to provide gain for each output signal individually to retain the differential signal, or a single amplifier difference amp can perform a differential to single-ended conversion and the other amplifier can perform differentiation of the single-ended signal. For multi-channel, parallel recorded data, the overall component count of the playback system can be minimized by using one amplifier of the LM359 per channel.

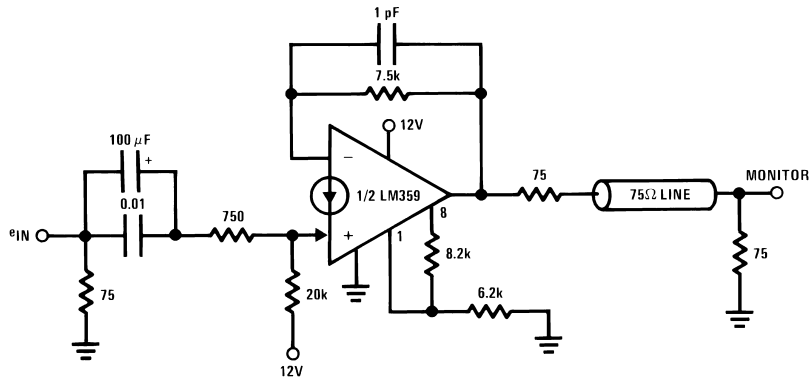

AN007490-8

**FIGURE 8. A Typical Application of this Fast Norton Amplifier as a High Performance Video Amplifier Driving a 75Ω Line**

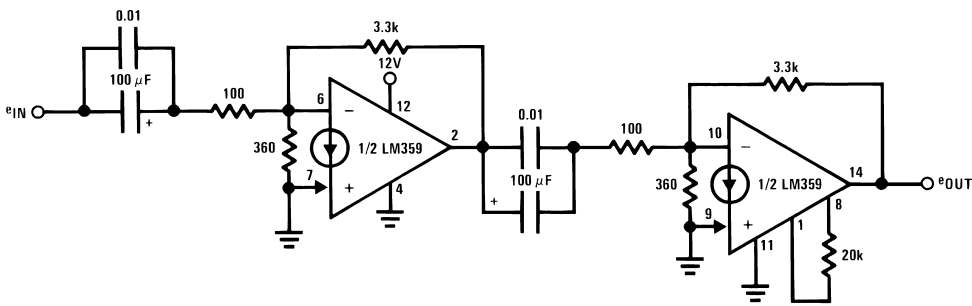

AN007490-9

$$\frac{e_{OUT}}{e_{IN}} \approx 1000$$

Circuit BW  $\approx$  8 MHz

**FIGURE 9. General Purpose, High Gain, Wideband Amplifiers Can Be Obtained by Cascading the 2 Norton Amplifiers Available on a Single Chip**

**Combining gain with constant delay filtering:** Another important application of the LM359 in data recovery systems is that of filtering. It is most desirable to prevent high frequency noise spikes from being coupled through the sensing stage causing erroneous readings, but the low pass filter used must not induce time delays to valid data signals which will be decoded by their time relationship to each other. This immediately implies a constant group delay low pass filter or a Bessel filter approximation which, if implemented with active components, can also provide signal gain. *Figure 10* shows a fourth order, 250 kHz, gain of 100 Bessel filter. Here, because of the low  $Q_o$  requirements of the Bessel filter, a simple (Sallen-Key) filter structure has been chosen over the previously discussed higher performance structures. Note, however, that constant group delay filtering and amplification are performed with a single package.

#### A HANDLE ON INPUT NOISE

The programmability of the amplifier's input stage current and the ability to "shut off" the non-inverting input current mirror allows significant improvements of the noise charac-

teristics. For an inverting application where the non-inverting input would only be used for DC biasing purposes, an alternate biasing scheme, the  $nV_{BE}$  biasing, can be used, as shown in *Figure 11*. This allows "shutting off" the input current mirror which, in itself, will reduce the input noise by a factor of two.

In addition, the input stage programming current can be increased to further reduce the noise voltage at the expense of an increase in input noise current and low frequency  $1/f$  noise, which are not a problem in low input impedance, wideband amplifiers. The typical effect on noise vs input stage current is illustrated in *Figure 12*.

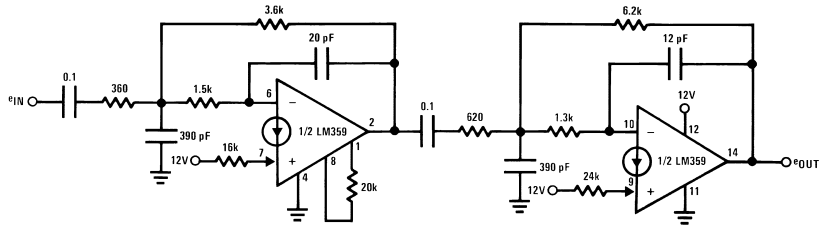

AN007490-10

$\frac{e_{OUT}}{e_{IN}} = 100$   
 $f_O = 250 \text{ kHz}$   
 Time delay = 636 ns  
 for  $f \leq 250 \text{ kHz}$

FIGURE 10. A Fourth Order, 250 kHz Bessel Filter for Data Recovery Systems. The Filtering Function is Done with a Single Package.

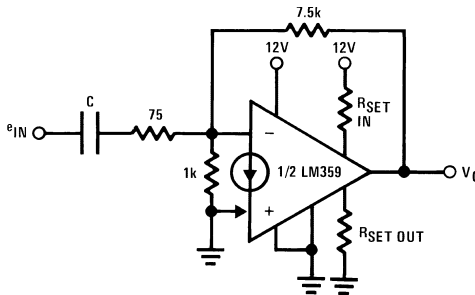

AN007490-11

FIGURE 11.  $nV_{BE}$  Biasing Can Reduce Input Noise Voltage

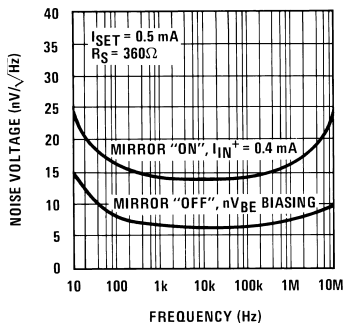

AN007490-12

a) Effect of "Shutting Off" the Input Mirror

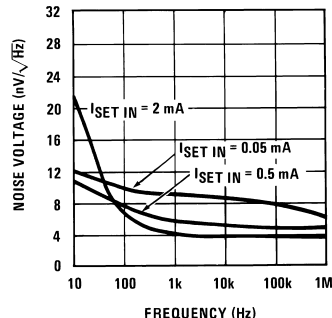

AN007490-18

b) Noise Performance of Figure 11

FIGURE 12. Programmability Provides a Handle on Input Noise

#### MAKING A FAST JFET INPUT OP AMP

The current mirror input stage of the LM359 can be used as an active load for a differential JFET stage to form a super fast op amp (Figure 13). This circuit combines the high frequency performance and programmability of the LM359 with the high input impedance and low bias currents of a discrete JFET input stage. External compensation of the LM359 is generally required to accommodate any additional phase

shift of the input stage, and the "pole-splitting" configuration shown works quite well. The speed performance is shown in Table 4. Note that this op amp should be mainly used for very high speed, single supply AC coupled circuits. This is because the op amp DC input offset voltage depends mainly on the matching of 2 discrete JFETs.

**TABLE 4. Typical Amplifier Performance**

$A_V$	BW	$S_r$	$C_c$
1	40 MHz	60 V/ $\mu$ s	51 pF
10	24 MHz	130 V/ $\mu$ s	5 pF
100	4.5 MHz	150 V/ $\mu$ s	2 pF

**A HIGH COMMON-MODE INPUT VOLTAGE DIFFERENCE AMPLIFIER**

An inherent feature of a current differencing input stage is that the voltages from which the input currents are derived are limited only by the maximum input current (or mirror current) of the amplifier and the size of the input resistors. An application that takes advantage of this is a high

common-mode voltage difference amplifier (Figure 14). In this circuit, the LM359 will amplify the difference in voltage between inputs V1 and V2, but both inputs can be riding on a common-mode level as high as approximately 250  $V_{DC}$  without exceeding the maximum mirror current of 10 mA.

The addition of resistor R1 in Figure 14 allows an adjustment of the common-mode rejection ratio by adjusting the inverting input bias current,  $I_{SET IN}$ . This bias current error is most significant at lower common-mode input voltage levels. By making the bias current directly proportional to the input level, a 20 dB CMRR improvement is possible by adjusting R1 for maximum CMRR at the maximum input common-mode voltage.

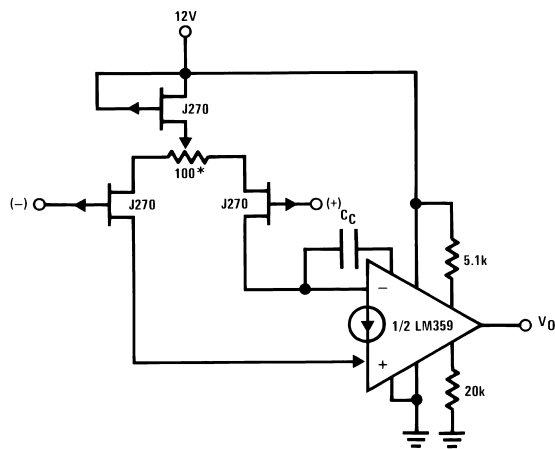

AN007490-13

\* $V_{OS}$  null ( $V_{OS}$  is typically < 25 mV)  
 $I_{BIAS}$  < 50 pA

**FIGURE 13. Combining the Norton Amplifier with Discrete P-Channel JFETs to Make a Fast Voltage Mode Op Amp**

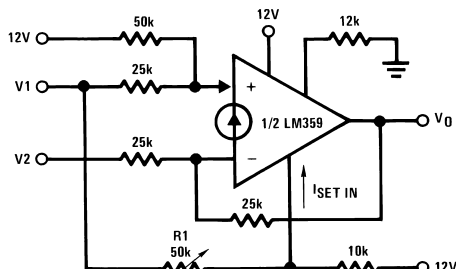

AN007490-14

**FIGURE 14. A High Input Common-Mode Voltage Difference Amplifier**

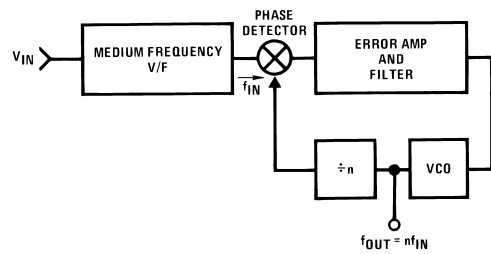

AN007490-15

**FIGURE 15. Using a Fast PLL to Make a High Frequency, Ultra Linear V/F**

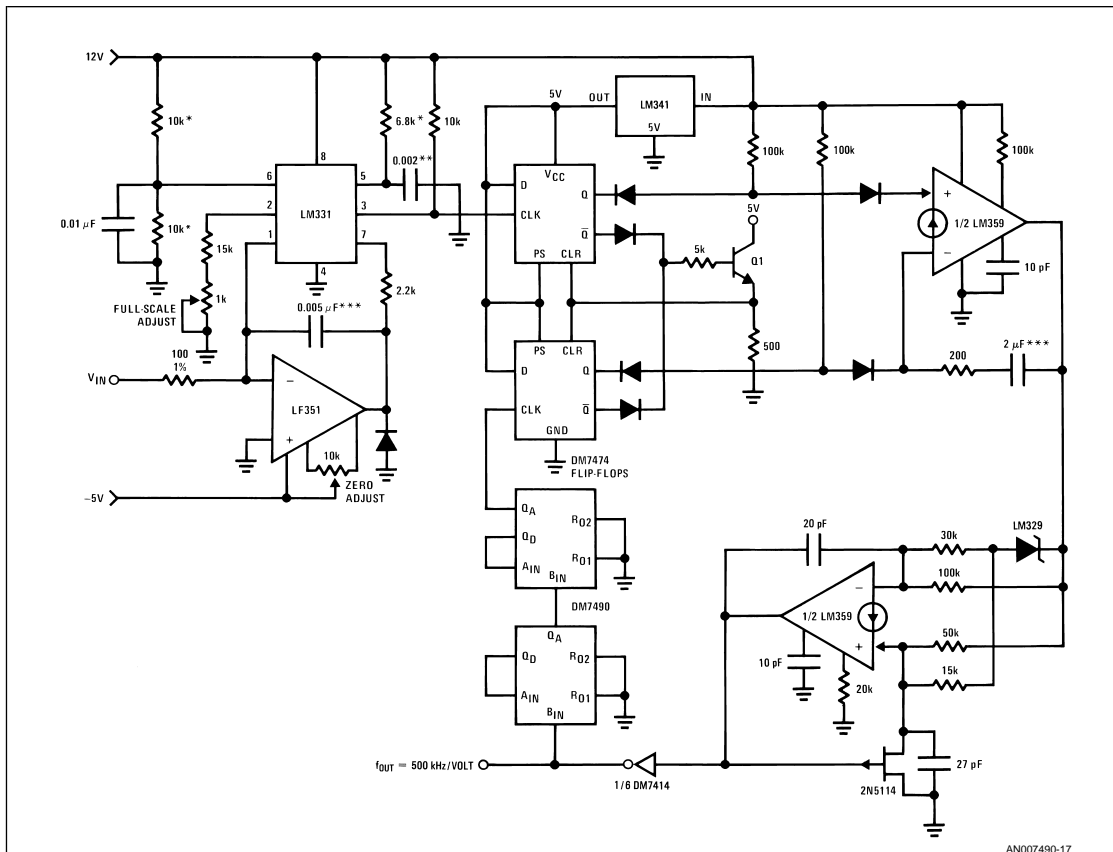

All diodes 1N914  
 \*Metal film, 1%  
 \*\*Polypropylene  
 \*\*\*Mylar  
 Q1→2N5038  
 Full-scale adjust made with  $V_{IN} = -10V$   
 Zero adjust made with  $V_{IN} = -0.1V$

FIGURE 16. Complete Schematic of an Ultra Linear, Two Decade (50 kHz→5 MHz) VCO

**BUILDING A FAST AND ULTRA LINEAR V/F CONVERTER**

Linear and fast voltage-to-frequency (V/F) converters are very difficult to build, especially when standard V/F design techniques are used. A solution to this problem is the use of a fast phase locked loop (PLL) which is driven by a medium frequency and ultra linear V/F IC (the LM331), Figure 15. This high frequency operation is obtained via a frequency divider inserted into the loop, and the linearity of the overall circuit closely approximates the linearity of the medium frequency input V/F. The high frequency, quasi linear VCO, and the error amplifier of the PLL are designed by using the 2 sections of the LM359. The output frequency of the VCO, which is also the output of the system, is divided by 100 and is compared with the output of the driving V/F via a digital phase detector. The overall circuit is shown in Figure 16. Following a zero and a full-scale adjust, the V/F works well over 2 decades of frequency and its non-linearity is below 0.03%, as shown in Figure 17.

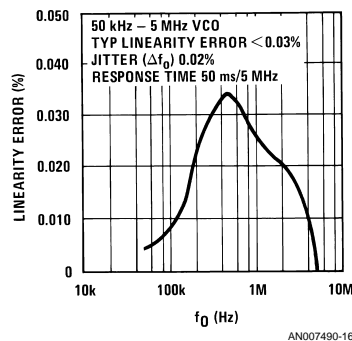

FIGURE 17. Typical Performance

**REFERENCES**

Fredericksen, T.M.; Howard, W.M.; Sleeth, R.S., "The LM3900—A New Current-Differencing Quad of  $\pm$  Input Amplifiers" AN-72, National Semiconductor Corporation.

Nortronics Design Digest on Digital Recording, Application Factors to Consider for Magnetic Heads, 1976.

Pease, R.A., "New Phase-Locked-Loops Have Advantages as Frequency to Voltage Converters (and more)" AN-210, National Semiconductor Corporation.

Book  
Extract  
End

**LIFE SUPPORT POLICY**

NATIONAL'S PRODUCTS ARE NOT AUTHORIZED FOR USE AS CRITICAL COMPONENTS IN LIFE SUPPORT DEVICES OR SYSTEMS WITHOUT THE EXPRESS WRITTEN APPROVAL OF THE PRESIDENT OF NATIONAL SEMICONDUCTOR CORPORATION. As used herein:

1. Life support devices or systems are devices or systems which, (a) are intended for surgical implant into the body, or (b) support or sustain life, and whose failure to perform when properly used in accordance with instructions for use provided in the labeling, can be reasonably expected to result in a significant injury to the user.
2. A critical component in any component of a life support device or system whose failure to perform can be reasonably expected to cause the failure of the life support device or system, or to affect its safety or effectiveness.

 <p><b>National Semiconductor Corporation</b> Americas Tel: 1-800-272-9959 Fax: 1-800-737-7018 Email: support@nsc.com</p>	<p><b>National Semiconductor Europe</b> Fax: +49 (0) 1 80-530 85 86 Email: europe.support@nsc.com Deutsch Tel: +49 (0) 1 80-530 85 85 English Tel: +49 (0) 1 80-532 78 32 Français Tel: +49 (0) 1 80-532 93 58 Italiano Tel: +49 (0) 1 80-534 16 80</p>	<p><b>National Semiconductor Asia Pacific Customer Response Group</b> Tel: 65-2544466 Fax: 65-2504466 Email: sea.support@nsc.com</p>	<p><b>National Semiconductor Japan Ltd.</b> Tel: 81-3-5620-6175 Fax: 81-3-5620-6179</p>
--	---	--	---

www.national.com

National does not assume any responsibility for use of any circuitry described, no circuit patent licenses are implied and National reserves the right at any time without notice to change said circuitry and specifications.