

Applying the New CMOS MICRO-DAC™

National Semiconductor
Application Note 271
Tim Regan
September 1981



Applying the New CMOS MICRO-DACS

AN-271

Most microprocessor based systems designers will find that the new CMOS MICRO-DAC are among the most interesting and versatile devices they will include in their system. The availability of these devices opens a vast new area of applications where the microprocessor can provide an intelligent controlling function in the analog world. Traditional analog control devices, primarily potentiometers and switches which require a time-consuming and often erroneous human interface, can often be replaced by a processor and DACs to perform precise and automatic controls. A little creative thinking can easily generate several functions that could be better performed automatically. The purpose of this note is to stimulate this thought and to illustrate the versatility of CMOS DACs to achieve results.

The use of CMOS processing in the fabrication of the MICRO-DAC offers several important features. The primary advantage is that the current switching R-2R ladder network, used for the actual D to A conversion, can conduct current in both directions (sourcing or sinking current at its analog output) to control either a positive or negative fixed voltage reference or an AC signal. In addition, all of the necessary digital input conditioning circuitry to permit a direct microprocessor interface with no additional logic devices needed is included with minimal device power requirements. All of the MICRO-DAC can be controlled from an 8-bit data bus regardless of the number of digital inputs for a particular device. The operation of the R-2R ladder and the digital interface signal requirements are explained in detail on the actual device data sheets.

Resolution and linearity are the most important characteristics of the analog output of any D to A. Linearity is important to insure that each and every analog output quantity is predictable within a given tolerance (specified as a percent of the full-scale range) for any applied digital word. Resolution defines the number of possible analog output quantities available within a given range. Higher resolution in a DAC serves to minimize the gaps in the analog output inherent in digitally-based controls. The new line of MICRO-DAC offers a wide variety of converters to fit the accuracy and resolution requirements of a great number of applications. The device part numbers are summarized in *Figure 1*.

In the application circuits that follow, the connections for the control pins for the actual digital interface are omitted for simplicity. Several methods of configuring the DAC to accept its inputs from a processor exist and are described on the data sheets. The actual method used depends on the overall system provisions and requirements. The digital input code is referred to as D and represents the decimal equivalent of the binary input. For example, D would range from 0 to 4095 in steps of 1 to describe the full range of digital inputs for a 12-bit MICRO-DAC. Any of the MICRO-DAC can be used in any of the circuits shown, depending on accuracy and/or resolution requirements.

THE DIGITAL POTENTIOMETER

The most common and basic application of a DAC is generating discrete voltage output levels within a given span, and serving in essence as an attenuator (*Figure 2*). The applied digital input word multiplies the applied reference voltage, and the output voltage is this product normalized to the DAC's resolution. The op amp shown is used to convert the output current from the DAC to a voltage via a feedback resistor included in the DAC (R_{FB}). This output current ranges from a near zero output leakage (on the order of 10 nA) for an applied code of all zeros ($D = 0$), to a full-scale value ($D = 2^n - 1$, where n is the DAC's bits of resolution) of V_{REF} divided by the R value of the internal R-2R ladder network (nominally 15 k Ω). The current at $I_{OUT 2}$ is equal to that caused by the one's complement of the applied digital input, so while $I_{OUT 1}$ is at full-scale, $I_{OUT 2}$ will be zero. Note that the output voltage is the opposite polarity of the applied reference voltage, but since CMOS DACs can accept bipolar reference voltages, if a positive output is needed, a negative reference can be applied. To preserve the linearity of the output, the two current output pins of the DAC must be as close to 0V as possible, which requires the input offset voltage of the op amp to be nulled. The amount of linearity error degradation is approximately $V_{OS} \div V_{REF}$. For AC signal attenuation, in audio applications for example, the DAC's linearity over the full range of the applied reference voltage, even as it passes through zero, is sufficiently good enough to distort a 10V peak sine wave by only 0.004%.

MICRO-DAC™ and BI-FET™ are trademarks of National Semiconductor Corp.

AN-271

Linearity Error (% of Full-Scale)	Resolution		
	8 Bits 256 Out- put Steps	10 Bits 1024 Out- put Steps	12 Bits 4096 Out- put Steps
±0.012%			DAC1208, DAC1230
±0.024%			DAC1209, DAC1231
±0.05%	DAC0830	DAC1000, DAC1006	DAC1210, DAC1232
±0.1%	DAC0831	DAC1001, DAC1007	
±0.2%	DAC0832	DAC1002, DAC1008	

FIGURE 1. The MICRO-DAC Family

The feedback capacitor shown in *Figure 2* is added to improve the settling time of the output as the input code is changed. With no compensation, a fair amount of overshoot and ringing appears at the output due to a feedback pole formed by the feedback resistor, and the output capacitance of the DAC, which appears from the (-) input of the op amp ground.

It is most desirable to select an op amp for use with the MICRO-DAC which combines good DC characteristics, primarily low V_{OS} and low V_{OS} drift, with fast AC characteristics such as slew rate, settling time and bandwidth. Such a combination is difficult to find in a single op amp for use with the higher accuracy 12-bit DACs. *Figure 3* shows an op amp configuration which combines the excellent DC input characteristics of the LM11 with the fast response of an LF351 BI-FET™ op amp.

The low cost, high resolution, and stability with time and temperature of the MICRO-DAC allow precise output levels that rival the capability of the best multiple turn potentiometers, and can automatically be adjusted, as required, by a controlling microprocessor.

LEVEL SHIFTING THE OUTPUT RANGE

As shown in *Figure 4*, the zero code output of the DAC can be shifted, if desired, to any level by summing a fixed current to the DAC's current output terminal, offsetting the output voltage of the op amp. The applied reference voltage now serves as the output span controller and is fractionally added to the output as a function of the applied code.

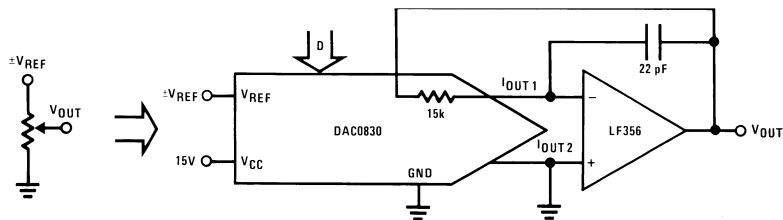

AN005629-10

$$V_{OUT} = \frac{-V_{REF}D}{256}$$

for $0 \leq D \leq 255$

FIGURE 2. The Digital Pot

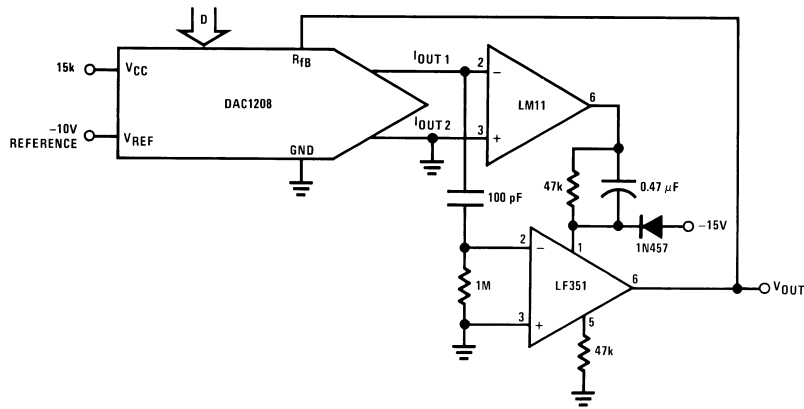

AN005629-12

Settling time = 8µs for a zero to full-scale transition

FIGURE 3. Composite Amplifier for Good DC Characteristics and Fast Output Response

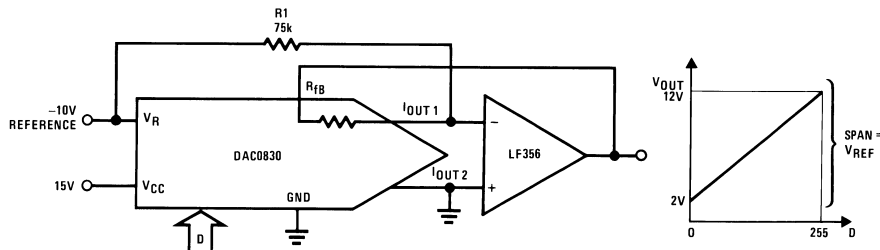

AN005629-13

$$V_{OUT} = -V_{REF} \left[\frac{R_{FB}}{R_1} + \frac{D}{256} \right]$$

FIGURE 4. Level Shifted Output

SINGLE SUPPLY OPERATION

The R-2R ladder can be operated as a voltage switching network to circumvent the output voltage inversion inherent in the current switching mode. This allows single supply operation. In *Figure 5*, the reference voltage is applied to the I_{OUT1} terminal, and is attenuated by the R-2R ladder in proportion to the applied code, and output to the V_{REF} terminal with no phase inversion. To insure linear operation in this mode, the applied reference voltage must be kept less than 3V for the 10-bit DACs or less than 5V for the 8-bit DACs. The applied supply voltage to the DAC must be at least 10V more positive than the reference voltage to insure that the CMOS ladder switches have enough voltage overdrive to fully turn on. An external op amp can be added to provide gain to the DAC output voltage for a wide overall output span.

The zero code output voltage is limited by the low level output saturation voltage of the op amp. The 2 kΩ load resistor helps to minimize this voltage. Specified DAC linearity can

be obtained in this circuit with the 8 and 10-bit MICRO-DAC, but is difficult because of the very low value reference required with the 12-bit parts. The resistance to ground of the V_{REF} terminal is nominally 15 kΩ, independent of the digital input code.

BIPOLAR OUTPUT FROM A FIXED REFERENCE VOLTAGE

The use of a second op amp in the analog output circuitry can provide a bipolar output swing from a fixed reference voltage. This, in effect, gives sign significance to the MSB of the digital input word to allow 2-quadrant multiplication of the reference voltage. The polarity of the reference can still be reversed or be an AC signal to realize full 4-quadrant multiplication. This circuit is shown in *Figure 6*.

Only the input offset voltage of amplifier OA 1 needs to be nulled to preserve the linearity of the DAC. The offset of OA 2 will affect only absolute accuracy of the output voltage.

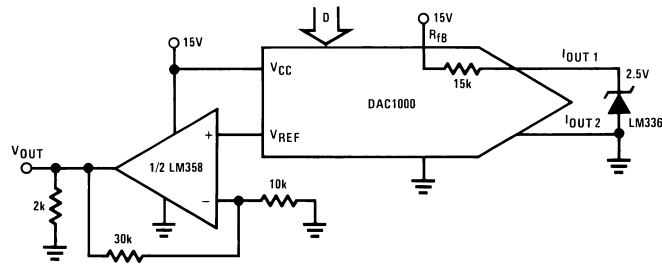

AN005629-15

$$V_{OUT} = +V_{REF} \left[\frac{4D}{1024} \right]$$

FIGURE 5. Single Supply Operation

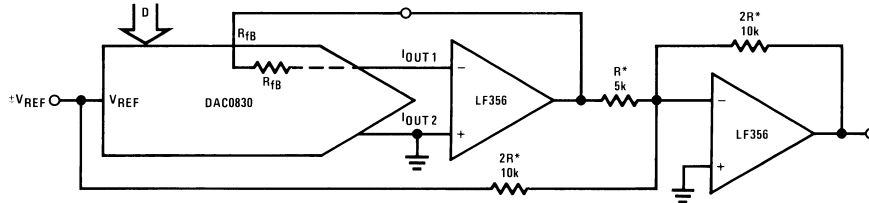

AN005629-17

$$V_{OUT} = V_{REF} \frac{(D - 128)}{128}$$

Input Code MSB . . . LSB	Ideal V_{OUT}	
	$+V_{REF}$	$-V_{REF}$
1 1 1 1 1 1 1 1	$V_{REF} - 1 \text{ LSB}$	$- V_{REF} + 1 \text{ LSB}$
1 1 0 0 0 0 0 0	$V_{REF}/2$	$- V_{REF} /2$
1 0 0 0 0 0 0 0	0	0
0 1 1 1 1 1 1 1	-1 LSB	$+1 \text{ LSB}$
0 0 1 1 1 1 1 1	$-\frac{ V_{REF} }{2} - 1 \text{ LSB}$	$\frac{ V_{REF} }{2} + 1 \text{ LSB}$
0 0 0 0 0 0 0 0	$- V_{REF} $	$+ V_{REF} $

*These resistors are available from Beckman Instruments, Inc. as their part no. 694-3-R10K-Q

$$1 \text{ LSB} = \frac{|V_{REF}|}{128}$$

FIGURE 6. Bipolar Output from a Fixed Reference Voltage

DAC CONTROLLED AMPLIFIER

In the circuit of Figure 7, the DAC is used as the feedback element for an inverting amplifier configuration. The R-2R ladder digitally adjusts the amount of output signal fed back to the amplifier's summing junction. The feedback resistance can be thought of as varying from $\approx 15 \text{ k}\Omega$ to ∞ as the input code changes from full-scale to zero. The internal R_{FB} is used as the amplifier's input resistor. It is important to note that when the input code is all zeros the feedback loop is opened and the op amp output will saturate.

CAPACITANCE MULTIPLIER

The DAC controlled amplifier can be used in a capacitance multiplier circuit to give a processor control of a system's time or frequency domain response. The circuit in Figure 8 uses the DAC to adjust the gain of a stage with a fixed capacitive feedback, creating a Miller equivalent input capacitance of the fixed capacitance times $1 +$ the amplifier's gain. The voltage across the equivalent input capacitance to ground is limited to the maximum output voltage of op amp A1, divided by $1 + 2^n/D$, where n is the DAC's bits of resolution.

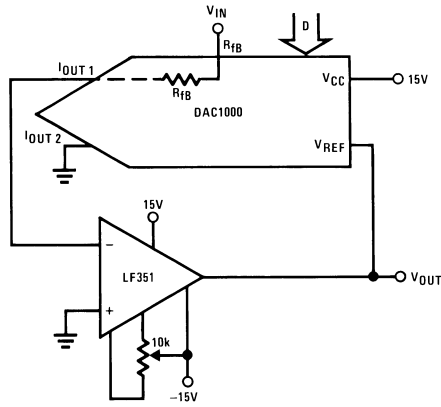

AN005629-22

$$V_{OUT} = \frac{-V_{IN}(1024)}{D}$$

FIGURE 7. DAC Controlled Amplifier

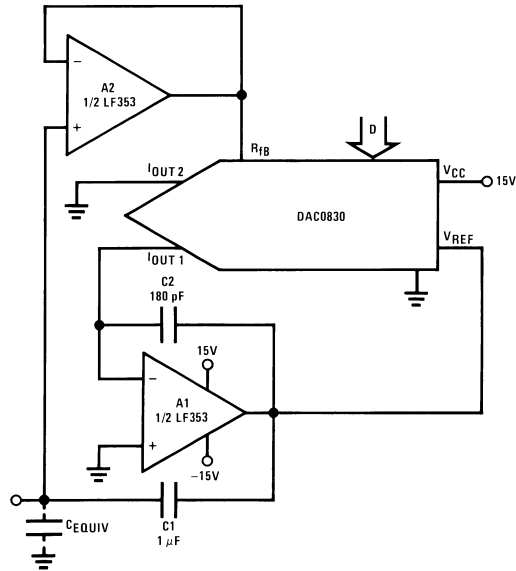

AN005629-24

$$C_{EQUIV} = C1 \left(1 + \frac{256}{D} \right)$$

FIGURE 8. Capacitance Multiplier

HIGH VOLTAGE OUTPUT

Many DAC applications involve the generation of high voltage levels to be used for deflection plate driving, high voltage motor speed, or position control. All of the MICRO-DAC can control as much as $\pm 25V$ applied to the reference terminal, but guaranteed performance is specified at no more

than $\pm 10V$. Since the output amplifier serves as a current-to-voltage converter, increasing the effective feedback resistance directly increases the amplifier's output voltage for a given DAC output current. Use of a high voltage op amp, the LM143 with 80V supply capability for example, can accommodate this increased gain and allow the use of refer-

ence voltage within the DAC's specified limits. *Figure 9* illustrates how higher voltage outputs can be obtained for both unipolar and bipolar requirements.

The output current of these circuits is limited to that of the LM143, typically 20 mA. If higher voltage and/or higher output current is needed, a discrete power stage can be used, as shown in *Figure 10*.

To insure accuracy with these high voltage circuits, concern for the power dissipation and temperature coefficients of the

resistors used to increase the output voltage is necessary. The T-network configuration shown in *Figure 10* reduces the dependence of the output voltage to temperature changes by reducing the significance of the tracking requirements of the external resistors to the internal R_{FB} resistor. Using two resistors with similar temperature coefficients for R1 and R2, and making their ratio dominant in setting the overall gain provide the most stable results.

a) Unipolar Output

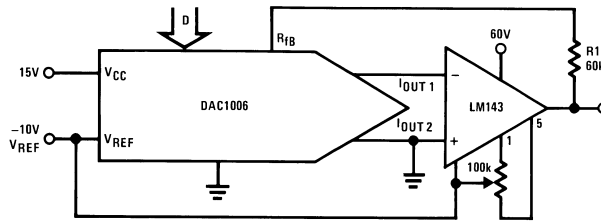

AN005629-26

$$V_{OUT} = \frac{-V_R D}{1024} (R_{FB} + R_1)$$

$$0 \leq V_{OUT} \leq 50V$$

b) Bipolar Output

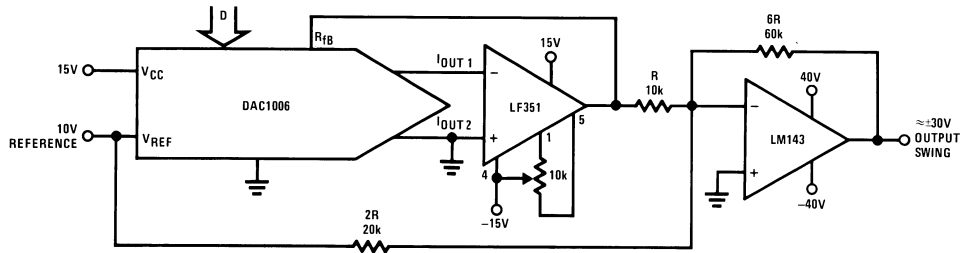

AN005629-28

$$V_{OUT} = \frac{(D - 512) 3 V_R}{512}$$

FIGURE 9. Unipolar and Bipolar Voltage Boosting

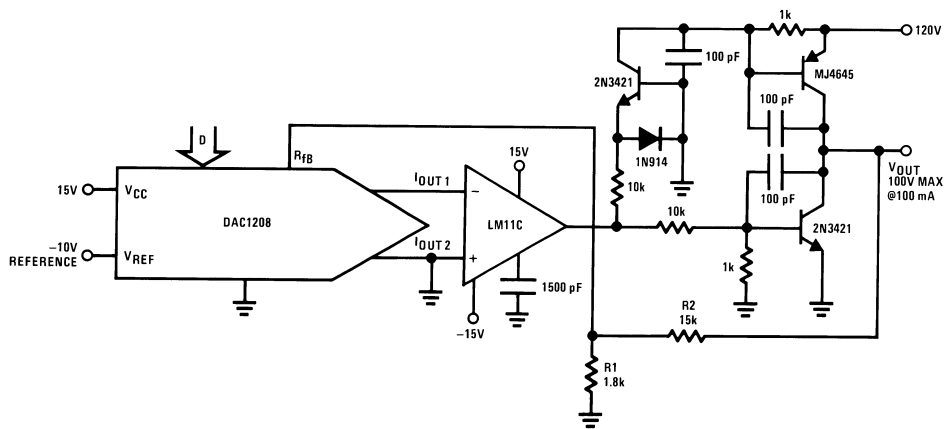

AN005629-30

$$V_{OUT} = \frac{-V_{REF}D}{4096} \left[1 + \frac{R_2}{R_{FB}} + \frac{R_2}{R_1} \right]$$

FIGURE 10. High Voltage Power DAC

HIGH CURRENT CONTROLLER

The MICRO-DAC can also be used to linearly control current flow useful in applications such as automatic test systems, stepper-motor torque compensation, and heater controls. Figure 11 illustrates the use of a DAC1230 controlling a 0A to 1A current sink. The largest source of nonlinearity in this circuit is the stability of the current sensing resistance with changes in its power dissipation. To minimize this effect, the sensing resistance should be kept as low as possible. To maintain the output current range, the reference voltage to the DAC must be reduced. The flexible reference requirements of the MICRO-DAC permit the application of a lower reference with no degradation in linearity. A triple Darlington is used to minimize the base current term flowing through the sense resistor, but not into the collector terminal.

4 ma to 20 mA CURRENT LOOP CONTROLLER

The standard 4 mA–20 mA industrial process current loop controller is an application where automatic, microprocessor directed operation is often required, and is a natural application for D to A converters. The low power requirements of the CMOS MICRO-DAC allow the design of a controller that is powered directly from the loop it is controlling. Figure 12 illustrates a 2-terminal floating 4 mA to 20 mA controller.

In this circuit, the output transistor will conduct whatever current is necessary to keep the voltage across R3 equal to the voltage across R2. This voltage, and therefore the total loop current, is directly proportional to the output current from the DAC. The net resistance of R1 is used to set the zero code loop current to 4 mA, and R2 is adjusted to provide the 16 mA output span with a full-scale DAC code.

The entire circuit “floats” by operating at whatever ground reference potential is required by the total loop resistance and loop current. To insure proper operation, the voltage differential between the input and output terminals must be kept in the range of 16V to 55V, and the digital inputs to the DAC must be electrically isolated from the ground potential of the controlling processor. This isolation can best be achieved with opto-isolators switching the digital inputs to the ground potential of the DAC for a logic low level.

In a non-microprocessor based system where the loop controlling information comes from thumbwheel switches, the digital input data for the DAC can be derived from BCD to binary CMOS logic circuitry, which is ground referenced to the ground potential of the DAC. The total supply current requirements of all circuits used must, of course, be less than 4 mA, and the value of R1 could be adjusted accordingly.

TARE COMPENSATION/AUTO-ZEROING

Probably the most popular application of D to A converters is in auto-zeroing or auto-referencing. In these systems the DAC is called upon to hold an output voltage used to offset the analog input range of an A to D converter. This is done to reserve the full input range of the A to D for analog voltages starting from reference potential to a full-scale value relative to that reference voltage. A common example of this is Tare Compensation in a weighing system where the weight of the scale platform, and possibly a container, is subtracted automatically from the total weight being measured. This, in effect, expands the range of weight that could be measured by preventing a premature full-scale reading, and allows an automatic indication of the actual unknown quantity.

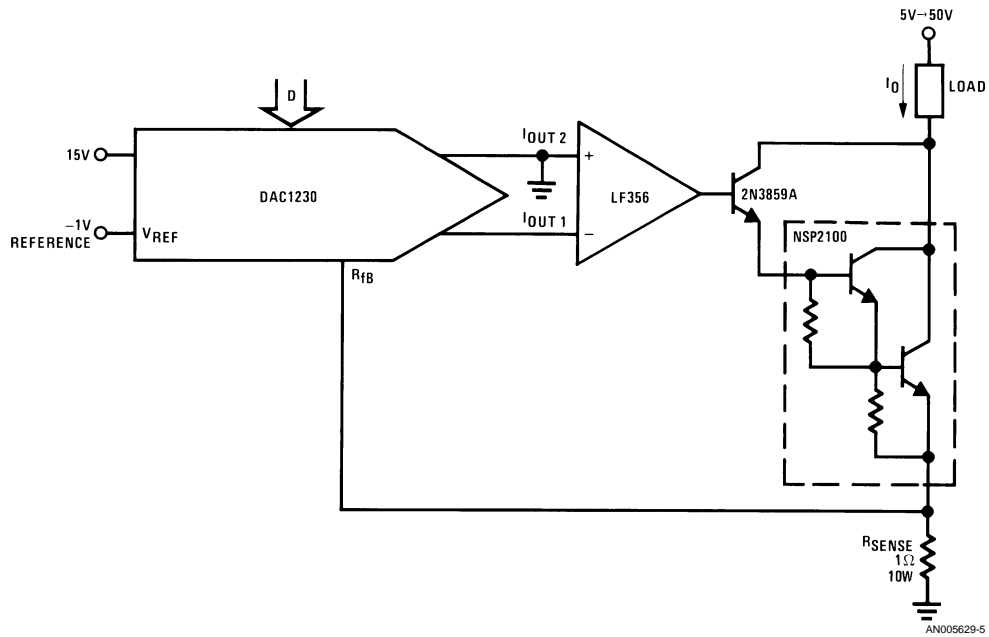

$$I_O = \frac{1A(D)}{4096}$$

FIGURE 11. High Current Controller

Figure 13 illustrates this basic technique. In this system the DAC would initially be given a zero code and the system's input would be set to some reference quantity. A conversion of this input would be performed, then the corresponding code would be applied to the DAC. The output of the DAC will be equal to and of the opposite polarity as the input voltage to force the amplifier's output, and therefore the A/D's input, to

zero. The DAC's output is held constant so that any subsequent A/D conversions will yield a value relative in magnitude to the initial reference quantity. To insure that the output code from the A to D generates the proper DAC output voltage, the two devices should be driven from the same reference voltage.

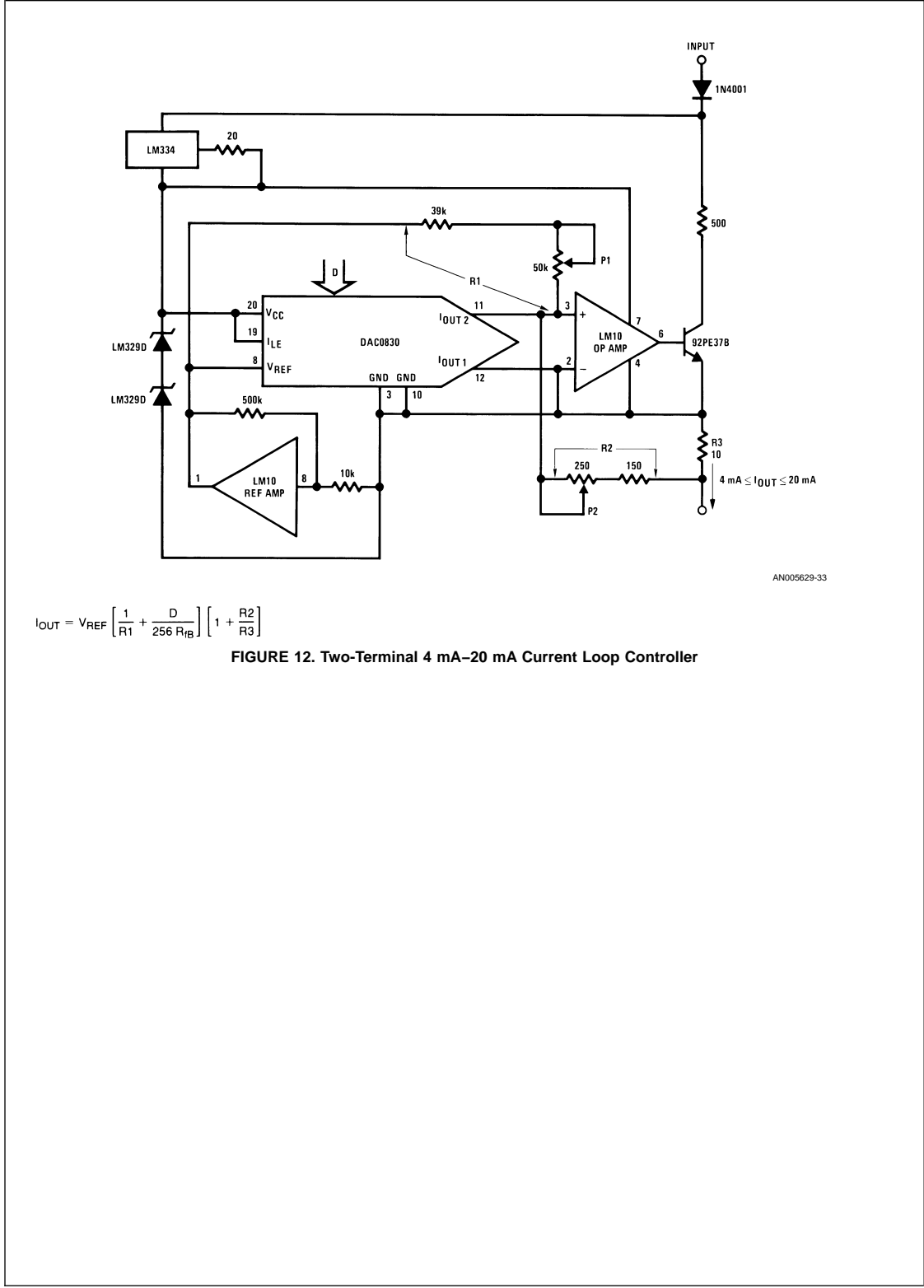

AN005629-33

$$I_{OUT} = V_{REF} \left[\frac{1}{R1} + \frac{D}{256 R_{1B}} \right] \left[1 + \frac{R2}{R3} \right]$$

FIGURE 12. Two-Terminal 4 mA-20 mA Current Loop Controller

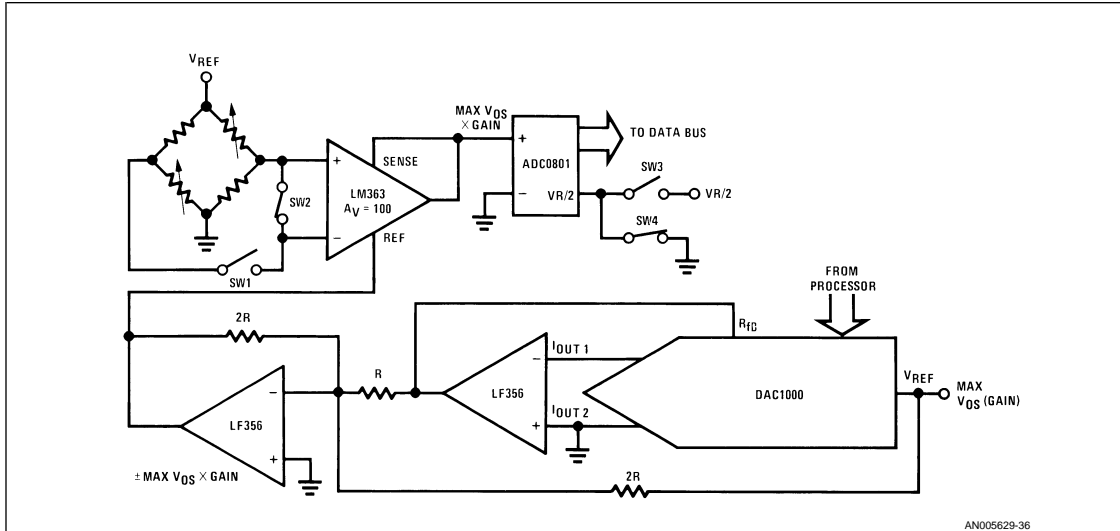

AN005629-36

SW2 and SW4 closed for auto-zeroing
SW1 and SW3 closed for signal measurement

FIGURE 14. Auto-Zeroing

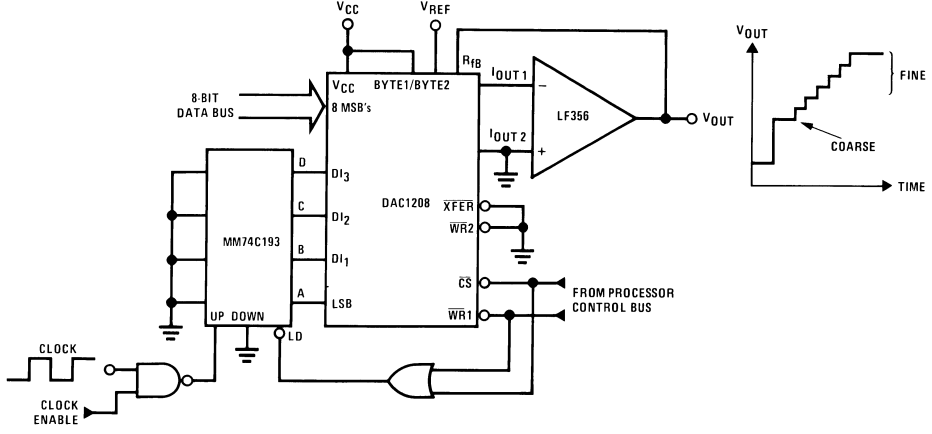

AN005629-37

FIGURE 15. 8-Bit Coarse, 4-Bit Vernier DAC

DAC CONTROLLED FUNCTION GENERATOR

CMOS DACs find wide use in the synthesis of periodic waveforms from digital information primarily for their precision and flexibility in controlling magnitude and timing parameters. If the signal generated is used as an excitation for a system, the data is readily available for a processor to know precisely where the input is to enable it to interpret the output response of the system. Typically, the data required to generate the amplitude information resides in the system ROM and the frequency is controlled by the rate at which the DAC is updated. Some of the more typical waveforms include sine, square, sawtooth ramps or staircases, and triangles.

Figure 16 shows the implementation of a MICRO-DAC providing frequency control of a sine, square and triangle function generator. The DAC is used as a digitally programmable input resistor for an integrator. The bipolar nature of the ref-

erence input is important to the generation of a symmetrical triangle wave and a symmetrically clamped square wave. This allows the integrating capacitor to be ground referenced with equal charging and discharging currents. Linearity of the output frequency versus the applied digital input code is as good as the DAC up to 30 kHz, where the propagation delay through the LM319 comparator starts adding non-linearity.

Integrating capacitor, C1, is selected for the maximum output frequency which occurs with a full-scale input code when the DAC provides its maximum output current. A problem in selecting this capacitor is that the R value of the internal R-2R ladder can vary over the range of 10 kΩ to 20 kΩ. This can be accommodated by adjusting the amount of positive feedback around the comparator to provide the desired maximum frequency for a given capacitor. This adjustment also

alters the amplitude of the triangle wave, but this can be attenuated or amplified as required to achieve any desired amplitude.

The sine wave output is derived from the triangle wave by virtue of the non-linear conduction characteristics of the transistors used in the shaper circuit. The wave-shape adjustment is used to obtain minimum distortion of the sine wave output and should be adjusted after the triangle wave output is established.

The square wave output is a 50% duty cycle, symmetrical $\pm 7V$ signal. Since only $\frac{1}{2}$ of the LM319 dual comparator is used, the other side can be used to provide TTL or CMOS logic compatible output if needed.

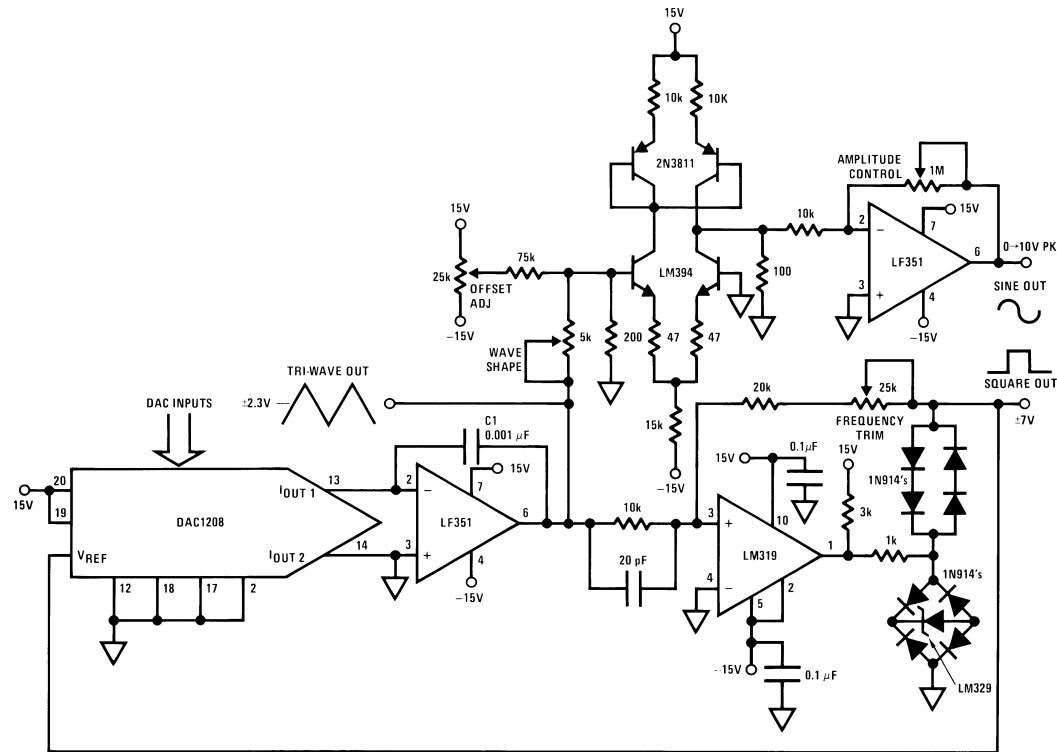

- C1 controls maximum frequency
- <0.5% sine wave THD over range
- Range 30 kHz maximum
- Linearity — DAC limit
- $f = \frac{4096}{4/3 R_{FB} C}$

FIGURE 16. DAC Controlled Function Generator

For DAC controlled amplitude versatility, the basic unipolar configuration (Figure 2) can be used at any or all of the outputs.

LOGARITHMIC AMPLIFIER WITH A PROGRAMMABLE SCALE FACTOR

Sensors that operate over a wide dynamic range, such as photomultiplier tubes, often require signal compression via logarithmic amplifiers. Figure 17 shows a logging amplifier with a digitally programmable output scale factor from 10 mV/decade to 10V/decade over an input voltage range of 100 μV to 10V, or an input current range of 10 nA to 1 mA. The DAC1006 is used as the scaling element to attenuate or amplify the logarithmic output.

SUMMARY

The circuits described in this note illustrate only a very small percentage of possible MICRO-DAC applications. The key points to remember when considering the use of one of these devices are summarized below.

1. The reference voltage can be a bipolar AC or DC signal within the range of 25V with specified linearity guaranteed at $\pm 10V$ and $\pm 1V$.
2. Low power consumption CMOS circuitry (20 mW typ).
3. Direct microprocessor interface with the necessary controlling logic designed in. All parts are 8-bit bus compatible.
4. TTL compatible digital input thresholds independent of

- the DAC's V_{CC} supply.
- Linearity is guaranteed over temperature following a simple zero and full-scale adjustment procedure.
 - The current outputs, I_{OUT1} and I_{OUT2} , want to be at ground potential.
 - I_{OUT1} should always be used in conjunction with the internally provided feedback resistor, as this resistor

- matches and tracks with temperature the resistors used in the R-2R ladder network.
- The internal R value can vary over a 10 k Ω to 20 k Ω range.
- The 12-bit MICRO-DAC are not recommended for use in the voltage switching mode.

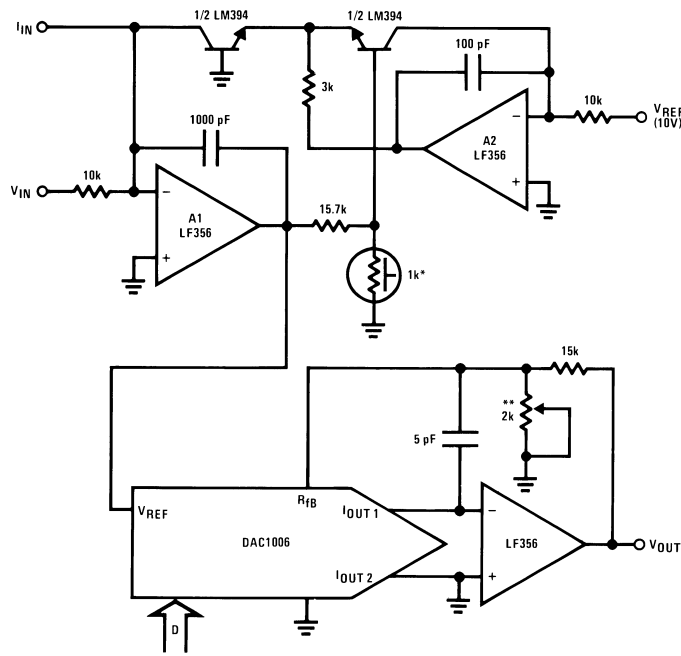

AN005629-9

*Tel Labs Q81 (+0.3%/°C)

**Adjust for 10V/dec output sensitivity at full-scale input code

$$V_{OUT} = \frac{10D}{1024} \log \frac{V_{IN}}{V_{REF}}$$

FIGURE 17. Logarithmic Amplifier with Digitally Programmable Scale Factor

LIFE SUPPORT POLICY

NATIONAL'S PRODUCTS ARE NOT AUTHORIZED FOR USE AS CRITICAL COMPONENTS IN LIFE SUPPORT DEVICES OR SYSTEMS WITHOUT THE EXPRESS WRITTEN APPROVAL OF THE PRESIDENT OF NATIONAL SEMICONDUCTOR CORPORATION. As used herein:

1. Life support devices or systems are devices or systems which, (a) are intended for surgical implant into the body, or (b) support or sustain life, and whose failure to perform when properly used in accordance with instructions for use provided in the labeling, can be reasonably expected to result in a significant injury to the user.
2. A critical component in any component of a life support device or system whose failure to perform can be reasonably expected to cause the failure of the life support device or system, or to affect its safety or effectiveness.

AN-271



National Semiconductor Corporation
Americas
Tel: 1-800-272-9959
Fax: 1-800-737-7018
Email: support@nsc.com

National Semiconductor Europe
Fax: +49 (0) 1 80-530 85 86
Email: europe.support@nsc.com
Deutsch Tel: +49 (0) 1 80-530 85 85
English Tel: +49 (0) 1 80-532 78 32
Français Tel: +49 (0) 1 80-532 93 58
Italiano Tel: +49 (0) 1 80-534 16 80

National Semiconductor Asia Pacific Customer Response Group
Tel: 65-2544466
Fax: 65-2504466
Email: sea.support@nsc.com

National Semiconductor Japan Ltd.
Tel: 81-3-5620-6175
Fax: 81-3-5620-6179

www.national.com

National does not assume any responsibility for use of any circuitry described, no circuit patent licenses are implied and National reserves the right at any time without notice to change said circuitry and specifications.