

# LM27342 Demonstration Board

National Semiconductor  
Application Note 1929  
Marc Davis-Marsh  
November 20, 2008



## Introduction

The LM27342 demonstration board is designed to provide the power supply design engineer with a fully functional regulator design which can be synchronized to an external clock between 1000 kHz and 2350 kHz. The evaluation board provides a 3.3V output with a 2A current capability. The wide input voltage ranges from 5V to 20V. Without an external synchronization signal, the design operates at 2000 kHz reducing the solution size and keeping switching noise out of the AM radio band. The printed circuit board consists of 4 layers of copper on FR4 material. There is a ground plane on the internal layer directly beneath the LM27342, and a ground plane on the bottom layer. The LM27342 is thermally tied to the ground planes by thermal vias directly underneath the

device. The second internal layer is tied half to  $V_{IN}$  and half to  $V_{OUT}$ . This application note contains the evaluation board schematic, a quick setup procedure, and a Bill-of-Materials (BOM). Refer to the LM27342 datasheet for complete circuit design information.

The performance of the evaluation board is as follows:

Input Range: 5 to 20V

Output Voltage: 3.3V

Output Current: 0 to 2A

Frequency of Operation: 1000 kHz - 2350 kHz

Board Size: 1.1 X 1.3 inches

## Evaluation Board Schematic

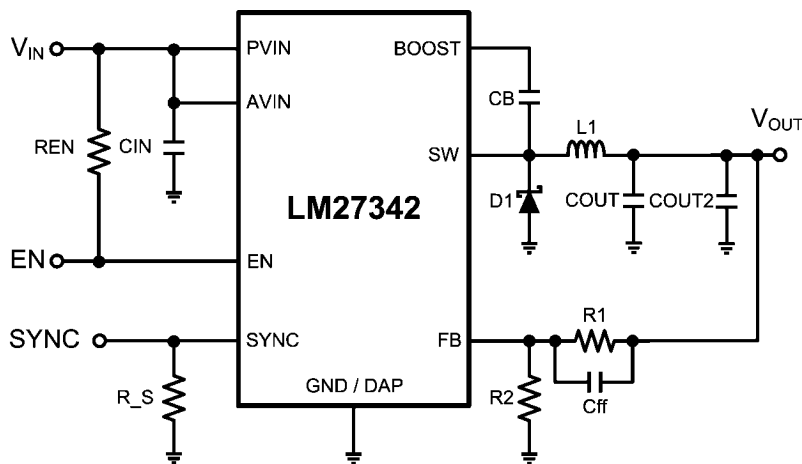

30087201

## Powering and Loading Considerations

Read this entire page prior to attempting to power the evaluation board.

### QUICK START PROCEDURE

**Step 1:** Set the bench power supply current limit to 2A. Set the power supply voltage to 12V. Turn off the power supply output. Connect the power supply to the LM27342 demo board. Positive connection to  $V_{IN}$  and negative connection to GND.

**Step 2:** Connect a load, as high as 2A, to the  $V_{OUT}$  terminal. Positive connection to  $V_{OUT}$  and negative connection to GND.

**Step 3:** Connect a signal generator to provide a synchronization signal to the SYNC terminal. Positive connection to SYNC and negative connection to GND.

**Step 4:** The EN pin should be left open for normal operation.

**Step 5:** Turn on the bench power supply with no load applied to the LM27342.  $V_{OUT}$  should be in regulation with a nominal 3.3V output.

**Step 6:** Slowly increase the load while monitoring the output voltage,  $V_{OUT}$  should remain in regulation with a nominal 3.3V output as the load is increased up to 2 Amps.

**Step 7:** Slowly sweep the input voltage from 5 to 20V and back to 12V,  $V_{OUT}$  should remain in regulation with a nominal 3.3V output.

**Step 8:** Turn on the signal generator, and synchronize the LM27342 to a 3.3V square wave at 1 MHz.  $V_{OUT}$  should remain in regulation with a nominal 3.3V output. Monitor SYNC and SW to observe the synchronization behavior.

### STARTING UP

The EN pin is tied to  $V_{IN}$  to simplify start-up. The pull-up resistor allows the power supply design engineer to toggle EN independently, if desired, and observe the start-up behavior of the LM27342.

**OVER CURRENT PROTECTION**

The evaluation board is configured with over-current protection. The inductor current is limited to 4.0A (max).

**SYNCHRONIZATION**

A SYNC pin has been provided on the evaluation board. This pin can be used to synchronize the regulator to an external clock or multiple evaluation boards can be synchronized together by connecting their SYNC pins together. Refer to the LM27342 datasheet for complete information

**ADJUSTING THE OUTPUT VOLTAGE**

The output voltage is set using the following equation where R2 is connected between the FB pin and GND, and R1 is connected between V<sub>OUT</sub> and FB.

$$R1 = \left( \frac{V_{OUT}}{V_{REF}} - 1 \right) \times R2$$

Adjusting the output voltage will affect the performance of the LM27342. In addition, output capacitors might not be rated for the new output voltage. Refer to the LM27342 datasheet for more information.

**Performance Characteristics**

**EFFICIENCY PLOTS**

Figure 1 shows the conversion efficiency versus output current for several input voltage conditions.

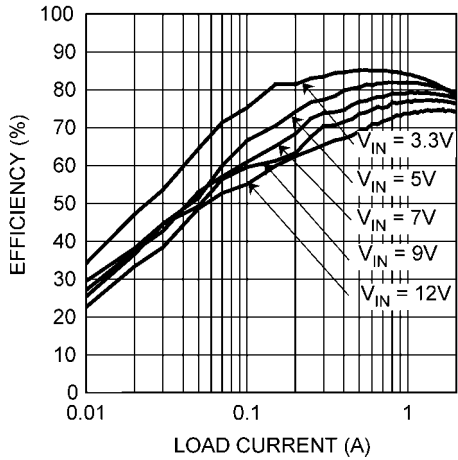

30087203

**FIGURE 1.**

**TURN-ON WAVEFORM**

When applying power to the LM27342 evaluation board a soft-start sequence occurs. Figure 2 shows the output voltage during a typical start-up sequence.

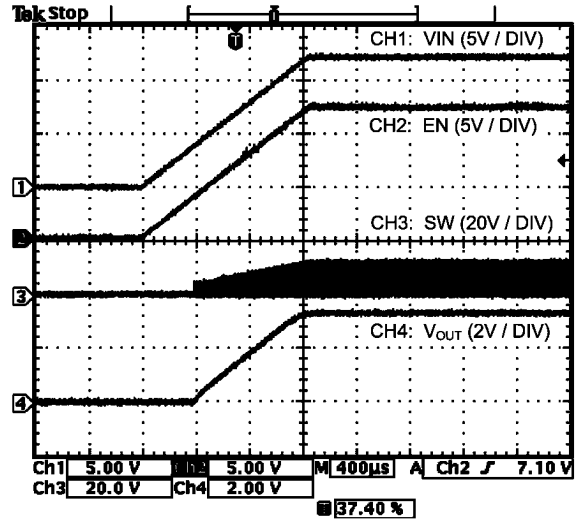

30087204

Output Current = 1A

**FIGURE 2.**

## Layout and Bill of Materials

The Bill of Materials is shown below, including the manufacturer and part number.

### Bill of Materials

Part Name	Part ID	Part Value	Part Number	Manufacturer
Buck Regulator	U1	2A Buck Regulator	LM27342	National Semiconductor
C <sub>IN</sub>	CIN	10 $\mu$ F	TMK325B7106MM-T	Taiyo Yuden
C <sub>BOOST</sub>	CB	0.1 $\mu$ F	C0603C104K8RACTU	Kemet
C <sub>OUT</sub>	COUT	22 $\mu$ F	GRM32ER71A226KE20L	Murata
C <sub>OUT2</sub>	COUT2	22 $\mu$ F	GRM32ER71A226KE20L	Murata
Catch Diode	D1	Schottky Diode Vf = 0.32V	CMS06	Toshiba
Inductor	L1	2.7 $\mu$ H	CDRH5D18BHPNP-2R7M	Sumida
Feedback Resistor	R1	430 $\Omega$	MCR03EZPFX4300	Rohm
Feedback Resistor	R2	187 $\Omega$	MCR03EZPFX1870	Rohm
Pull-up Resistor	REN	4.7 k $\Omega$	MCR03EZPFX4701	Rohm
Pull-down Resistor	R_S	4.7 k $\Omega$	MCR03EZPFX4701	Rohm
Connectors	VIN, GND, GND, VOUT, EN, SYNC	Turret	160-2043-02-01-00	Cambion
Test Point	SW	Miniature Test Point	5000	Keystone

# PCB Layout

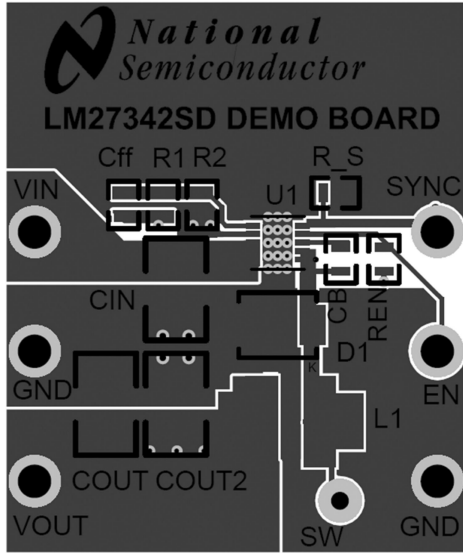

Top Layer and Overlay

30087205

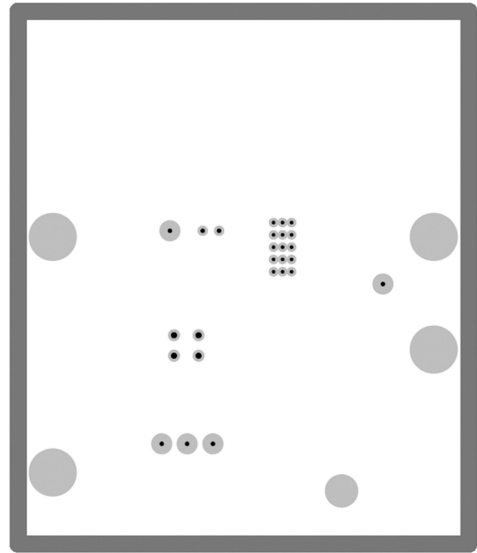

Internal Layer 1

30087206

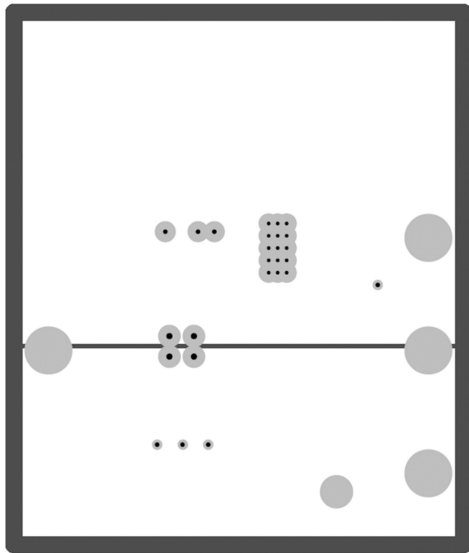

Internal Layer 2

30087207

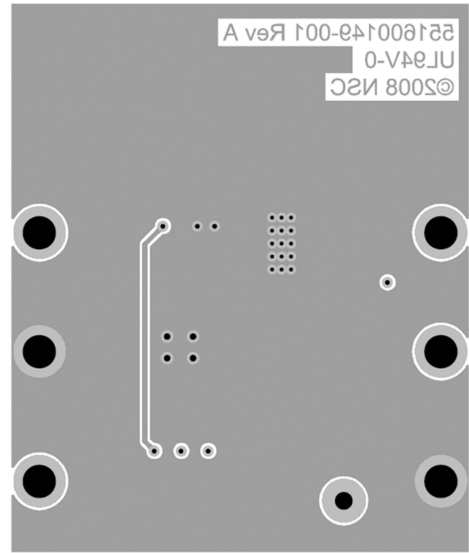

Bottom Layer

30087208

# Notes

AN-1929

# Notes

For more National Semiconductor product information and proven design tools, visit the following Web sites at:

Products		Design Support	
Amplifiers	<a href="http://www.national.com/amplifiers">www.national.com/amplifiers</a>	WEBENCH® Tools	<a href="http://www.national.com/webench">www.national.com/webench</a>
Audio	<a href="http://www.national.com/audio">www.national.com/audio</a>	App Notes	<a href="http://www.national.com/appnotes">www.national.com/appnotes</a>
Clock and Timing	<a href="http://www.national.com/timing">www.national.com/timing</a>	Reference Designs	<a href="http://www.national.com/refdesigns">www.national.com/refdesigns</a>
Data Converters	<a href="http://www.national.com/adc">www.national.com/adc</a>	Samples	<a href="http://www.national.com/samples">www.national.com/samples</a>
Interface	<a href="http://www.national.com/interface">www.national.com/interface</a>	Eval Boards	<a href="http://www.national.com/evalboards">www.national.com/evalboards</a>
LVDS	<a href="http://www.national.com/lvds">www.national.com/lvds</a>	Packaging	<a href="http://www.national.com/packaging">www.national.com/packaging</a>
Power Management	<a href="http://www.national.com/power">www.national.com/power</a>	Green Compliance	<a href="http://www.national.com/quality/green">www.national.com/quality/green</a>
Switching Regulators	<a href="http://www.national.com/switchers">www.national.com/switchers</a>	Distributors	<a href="http://www.national.com/contacts">www.national.com/contacts</a>
LDOs	<a href="http://www.national.com/ldo">www.national.com/ldo</a>	Quality and Reliability	<a href="http://www.national.com/quality">www.national.com/quality</a>
LED Lighting	<a href="http://www.national.com/led">www.national.com/led</a>	Feedback/Support	<a href="http://www.national.com/feedback">www.national.com/feedback</a>
Voltage Reference	<a href="http://www.national.com/vref">www.national.com/vref</a>	Design Made Easy	<a href="http://www.national.com/easy">www.national.com/easy</a>
PowerWise® Solutions	<a href="http://www.national.com/powerwise">www.national.com/powerwise</a>	Solutions	<a href="http://www.national.com/solutions">www.national.com/solutions</a>
Serial Digital Interface (SDI)	<a href="http://www.national.com/sdi">www.national.com/sdi</a>	Mil/Aero	<a href="http://www.national.com/milaero">www.national.com/milaero</a>
Temperature Sensors	<a href="http://www.national.com/tempsensors">www.national.com/tempsensors</a>	Solar Magic®	<a href="http://www.national.com/solarmagic">www.national.com/solarmagic</a>
Wireless (PLL/VCO)	<a href="http://www.national.com/wireless">www.national.com/wireless</a>	Analog University®	<a href="http://www.national.com/AU">www.national.com/AU</a>

THE CONTENTS OF THIS DOCUMENT ARE PROVIDED IN CONNECTION WITH NATIONAL SEMICONDUCTOR CORPORATION ("NATIONAL") PRODUCTS. NATIONAL MAKES NO REPRESENTATIONS OR WARRANTIES WITH RESPECT TO THE ACCURACY OR COMPLETENESS OF THE CONTENTS OF THIS PUBLICATION AND RESERVES THE RIGHT TO MAKE CHANGES TO SPECIFICATIONS AND PRODUCT DESCRIPTIONS AT ANY TIME WITHOUT NOTICE. NO LICENSE, WHETHER EXPRESS, IMPLIED, ARISING BY ESTOPPEL OR OTHERWISE, TO ANY INTELLECTUAL PROPERTY RIGHTS IS GRANTED BY THIS DOCUMENT.

TESTING AND OTHER QUALITY CONTROLS ARE USED TO THE EXTENT NATIONAL DEEMS NECESSARY TO SUPPORT NATIONAL'S PRODUCT WARRANTY. EXCEPT WHERE MANDATED BY GOVERNMENT REQUIREMENTS, TESTING OF ALL PARAMETERS OF EACH PRODUCT IS NOT NECESSARILY PERFORMED. NATIONAL ASSUMES NO LIABILITY FOR APPLICATIONS ASSISTANCE OR BUYER PRODUCT DESIGN. BUYERS ARE RESPONSIBLE FOR THEIR PRODUCTS AND APPLICATIONS USING NATIONAL COMPONENTS. PRIOR TO USING OR DISTRIBUTING ANY PRODUCTS THAT INCLUDE NATIONAL COMPONENTS, BUYERS SHOULD PROVIDE ADEQUATE DESIGN, TESTING AND OPERATING SAFEGUARDS.

EXCEPT AS PROVIDED IN NATIONAL'S TERMS AND CONDITIONS OF SALE FOR SUCH PRODUCTS, NATIONAL ASSUMES NO LIABILITY WHATSOEVER, AND NATIONAL DISCLAIMS ANY EXPRESS OR IMPLIED WARRANTY RELATING TO THE SALE AND/OR USE OF NATIONAL PRODUCTS INCLUDING LIABILITY OR WARRANTIES RELATING TO FITNESS FOR A PARTICULAR PURPOSE, MERCHANTABILITY, OR INFRINGEMENT OF ANY PATENT, COPYRIGHT OR OTHER INTELLECTUAL PROPERTY RIGHT.

## LIFE SUPPORT POLICY

**NATIONAL'S PRODUCTS ARE NOT AUTHORIZED FOR USE AS CRITICAL COMPONENTS IN LIFE SUPPORT DEVICES OR SYSTEMS WITHOUT THE EXPRESS PRIOR WRITTEN APPROVAL OF THE CHIEF EXECUTIVE OFFICER AND GENERAL COUNSEL OF NATIONAL SEMICONDUCTOR CORPORATION.** As used herein:

Life support devices or systems are devices which (a) are intended for surgical implant into the body, or (b) support or sustain life and whose failure to perform when properly used in accordance with instructions for use provided in the labeling can be reasonably expected to result in a significant injury to the user. A critical component is any component in a life support device or system whose failure to perform can be reasonably expected to cause the failure of the life support device or system or to affect its safety or effectiveness.

National Semiconductor and the National Semiconductor logo are registered trademarks of National Semiconductor Corporation. All other brand or product names may be trademarks or registered trademarks of their respective holders.

Copyright© 2008 National Semiconductor Corporation

For the most current product information visit us at [www.national.com](http://www.national.com)



**National Semiconductor  
Americas Technical  
Support Center**  
Email: [support@nsc.com](mailto:support@nsc.com)  
Tel: 1-800-272-9959

**National Semiconductor Europe  
Technical Support Center**  
Email: [europe.support@nsc.com](mailto:europe.support@nsc.com)  
German Tel: +49 (0) 180 5010 771  
English Tel: +44 (0) 870 850 4288

**National Semiconductor Asia  
Pacific Technical Support Center**  
Email: [ap.support@nsc.com](mailto:ap.support@nsc.com)

**National Semiconductor Japan  
Technical Support Center**  
Email: [jpn.feedback@nsc.com](mailto:jpn.feedback@nsc.com)