

LP38856S-1.2 Evaluation Board

National Semiconductor
Application Note 1479
Don Jones
November 2006



Introduction

This board is designed to allow the evaluation of the LP38856S-1.2 Voltage Regulator. Each board is assembled and tested in the factory. This evaluation board has the TO-263 5-lead package mounted.

General Description

The LP38856 is a dual-rail LDO linear regulator capable of supplying up to 3A of output current, and incorporates an Enable function

The device has been designed to work with 10 μ F input and output ceramic capacitors, and 1 μ F bias capacitors. Footprints areas for C_{IN} and C_{OUT} will allow for a variety of sizes.

Operation

The input voltage, applied between V_{IN} and GND, should be at least 1.0V greater than V_{OUT} , and no higher than the applied V_{BIAS} voltage.

The bias voltage, applied between V_{BIAS} and GND should be above the minimum bias voltage of 3.0V, and no higher than the maximum of 5.5V.

Loads can be connected to V_{OUT} with reference to GND.

V_{OUT} and V_{IN} test points are provided on the board to allow accurate measurements directly on the evaluation board, eliminating any voltage drop on the PCB traces or connecting wires to the load.

ON/OFF control is provided by supplying a logic level signal to the Enable pin. A minimum V_{EN} value of 1.3V is required at this pin to enable the LDO output. The LDO output will be shutdown when the V_{EN} value is 1.0V or less. The V_{EN} threshold incorporates approximately 100mV of hysteresis.

Schematic Diagram

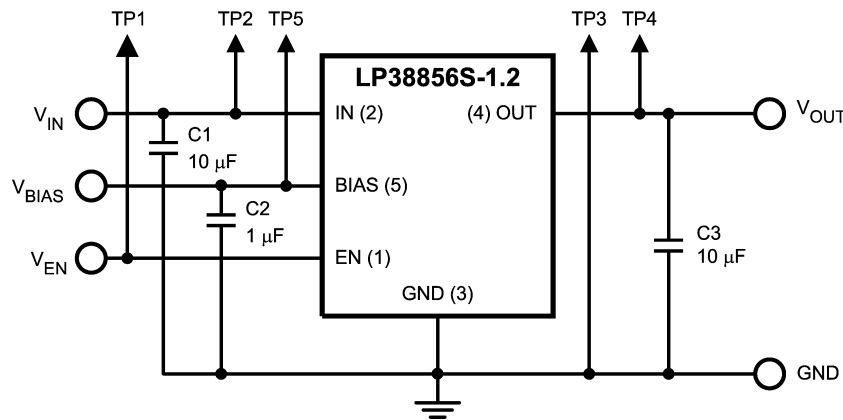

Evaluation Board Schematic.

20193501

In applications where the LP38856 is operated continuously the Enable pin can be connected directly to V_{BIAS} , or left open. The Enable pin has a 200 k Ω internal resistor to V_{BIAS} . If the Enable pin is left open, care should be taken to minimize any capacitance on the Enable pin, as any capacitance will introduce an RC delay time on the Enable function.

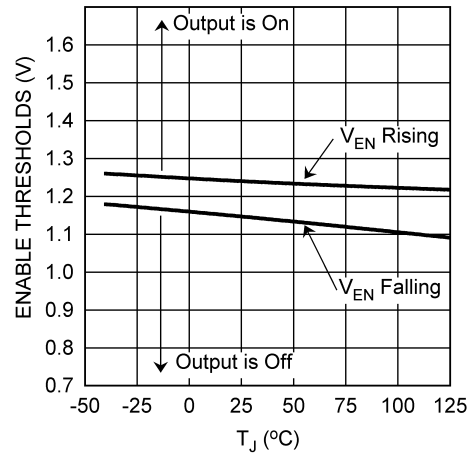

20193505

FIGURE 1. Enable Thresholds

Hardware

The schematic and layout of the evaluation board are given below:

PCB Layout

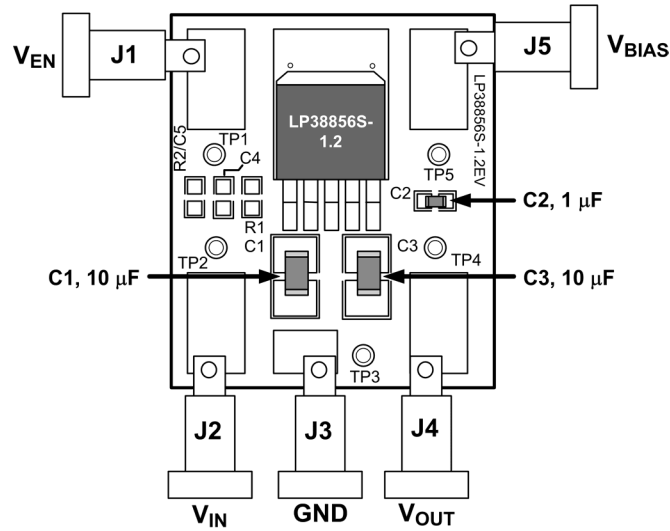

20193502

Evaluation Board Component and Pin Layout

Power Dissipation

The TO-263 package alone has a junction to ambient thermal resistance (θ_{JA}) rating of 60°C/W. When mounted on the LP38856S evaluation board the θ_{JA} rating is approximately 37°C/W.

Although there is only approximately 0.28 square inches of copper area immediately under the tab, the top copper surface area is extended to additional copper area on the bottom of the board by five thermal vias.

With the 37°C/W thermal rating the LP38856S evaluation board will dissipate a maximum of 2.75W with $T_A = 25^\circ\text{C}$.

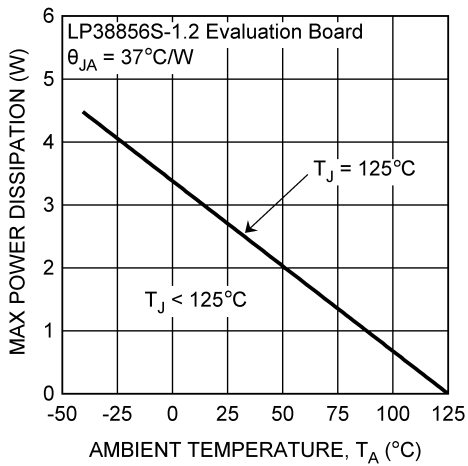

20193506

FIGURE 2. Maximum Power Dissipation vs Ambient Temperature

Bill of Materials

ID	Name	Description	Manufacturer	Part Number
U1	U1	LP38856S-1.2 NOPB	National Semiconductor Corporation	LP38856S-1.2 NOPB
C1	C _{IN}	10 μ F, 10%, MLCC, 10V, X7R, 1210	AVX	1210ZC106KAT2A
C2	C _{BIAS}	1 μ F, 10%, MLCC, 10V, X7R, 0805	AVX	0805ZC105KAT2A
C3	C _{OUT}	10 μ F, 10%, MLCC, 10V, X7R, 1210	AVX	1210ZC106KAT2A
C4	—	Not Installed	—	—
C5	—	Not Installed	—	—
J1	V _{EN}	Banana Jack : Insulated Solder Terminal - WHITE	Johnson Components	108-0901-001
J2	V _{IN}	Banana Jack : Insulated Solder Terminal - RED		108-0902-001
J3	GND	Banana Jack : Insulated Solder Terminal - BLACK		108-0903-001
J4	V _{OUT}	Banana Jack : Insulated Solder Terminal - ORANGE		108-0906-001
J5	V _{BIAS}	Banana Jack : Insulated Solder Terminal - BLUE		108-0910-001
R1	—	Not Installed	—	—
R2	—	Not Installed	—	—
TP1	TP _{EN}	Turret Terminal : Mounting Hole Diameter = 0.062"	Keystone	1593-2
TP2	TP _{IN}			
TP3	TP _{GND}			
TP4	TP _{OUT}			
TP5	TP _{BIAS}			

THE CONTENTS OF THIS DOCUMENT ARE PROVIDED IN CONNECTION WITH NATIONAL SEMICONDUCTOR CORPORATION ("NATIONAL") PRODUCTS. NATIONAL MAKES NO REPRESENTATIONS OR WARRANTIES WITH RESPECT TO THE ACCURACY OR COMPLETENESS OF THE CONTENTS OF THIS PUBLICATION AND RESERVES THE RIGHT TO MAKE CHANGES TO SPECIFICATIONS AND PRODUCT DESCRIPTIONS AT ANY TIME WITHOUT NOTICE. NO LICENSE, WHETHER EXPRESS, IMPLIED, ARISING BY ESTOPPEL OR OTHERWISE, TO ANY INTELLECTUAL PROPERTY RIGHTS IS GRANTED BY THIS DOCUMENT.

TESTING AND OTHER QUALITY CONTROLS ARE USED TO THE EXTENT NATIONAL DEEMS NECESSARY TO SUPPORT NATIONAL'S PRODUCT WARRANTY. EXCEPT WHERE MANDATED BY GOVERNMENT REQUIREMENTS, TESTING OF ALL PARAMETERS OF EACH PRODUCT IS NOT NECESSARILY PERFORMED. NATIONAL ASSUMES NO LIABILITY FOR APPLICATIONS ASSISTANCE OR BUYER PRODUCT DESIGN. BUYERS ARE RESPONSIBLE FOR THEIR PRODUCTS AND APPLICATIONS USING NATIONAL COMPONENTS. PRIOR TO USING OR DISTRIBUTING ANY PRODUCTS THAT INCLUDE NATIONAL COMPONENTS, BUYERS SHOULD PROVIDE ADEQUATE DESIGN, TESTING AND OPERATING SAFEGUARDS.

EXCEPT AS PROVIDED IN NATIONAL'S TERMS AND CONDITIONS OF SALE FOR SUCH PRODUCTS, NATIONAL ASSUMES NO LIABILITY WHATSOEVER, AND NATIONAL DISCLAIMS ANY EXPRESS OR IMPLIED WARRANTY RELATING TO THE SALE AND/OR USE OF NATIONAL PRODUCTS INCLUDING LIABILITY OR WARRANTIES RELATING TO FITNESS FOR A PARTICULAR PURPOSE, MERCHANTABILITY, OR INFRINGEMENT OF ANY PATENT, COPYRIGHT OR OTHER INTELLECTUAL PROPERTY RIGHT.

LIFE SUPPORT POLICY

NATIONAL'S PRODUCTS ARE NOT AUTHORIZED FOR USE AS CRITICAL COMPONENTS IN LIFE SUPPORT DEVICES OR SYSTEMS WITHOUT THE EXPRESS PRIOR WRITTEN APPROVAL OF THE CHIEF EXECUTIVE OFFICER AND GENERAL COUNSEL OF NATIONAL SEMICONDUCTOR CORPORATION. As used herein:

Life support devices or systems are devices which (a) are intended for surgical implant into the body, or (b) support or sustain life and whose failure to perform when properly used in accordance with instructions for use provided in the labeling can be reasonably expected to result in a significant injury to the user. A critical component is any component in a life support device or system whose failure to perform can be reasonably expected to cause the failure of the life support device or system or to affect its safety or effectiveness.

National Semiconductor and the National Semiconductor logo are trademarks or registered trademarks of National Semiconductor Corporation. All other brand or product names may be trademarks or registered trademarks of their respective holders.

Copyright © 2006 National Semiconductor Corporation.

For the most current product information visit us at www.national.com.



National Semiconductor
Americas Customer
Support Center
Email: new.feedback@nsc.com
Tel: 1-800-272-9959

www.national.com

National Semiconductor
Europe Customer Support Center
Fax: +49 (0) 180-530 85 86
Email: europa.support@nsc.com
Deutsch Tel: +49 (0) 69 9508 6208
English Tel: +44 (0) 870 24 0 2171
Français Tel: +33 (0) 1 41 91 8790

National Semiconductor
Asia Pacific Customer
Support Center
Email: ap.support@nsc.com

National Semiconductor
Japan Customer Support Center
Fax: 81-3-5639-7507
Email: jpn.feedback@nsc.com
Tel: 81-3-5639-7560